



Next Ord:2113-26
Next Res:1180-26

CITY COUNCIL AGENDA

February 11, 2026

6:00 PM

**Sedro-Woolley Municipal Building
Council Chambers
325 Metcalf Street**

- a. Call to Order**
- b. Pledge of Allegiance**
- c. Roll Call**
- d. Approval of Agenda**
- e. Consent Agenda**

Note: Items on the Consent Agenda are considered routine in nature and may be adopted by the Council by a single motion, unless any Councilmember wishes an item to be removed. The Council on the Regular Agenda will consider any item so removed after the Consent Agenda.

- 1. Minutes - Special City Council Meeting - January 28, 2026
- 2. Minutes - Regular City Council Meeting - January 28, 2026
- 3. Check Register - Regular

- f. Introduction of Special Guests and Presentation**

- 1. Central Skagit Library Director Dan Owens and Board of Trustees Chair Heather Swenson

- g. City Administrator Report**

- h. Councilmember and Mayor's Report**

- i. Proclamation(s)**

- j. Public Comments**

Please keep comments to three minutes or less. Because State law prohibits the use of city facilities for the purpose of supporting or opposing a campaign or ballot proposition, we respectfully request that public comment not make reference to such matters.

Written comments will be accepted by letter or via email at finance@sedro-woolley.gov Attn: 'Public Comment' until 4:30pm the day before the meeting.

- k. Public Hearing(s)**

- l. Unfinished Business**

- m. New Business**

- 1. Site Host Agreement – Amperage Group - Electric Vehicle Chargers

- n. Information Only Items**

- o. Good of the Order**

Call for council members and staff to present items for discussion or for council members to make a motion to add an item to a future council agenda.

p. Executive Session

q. Adjournment

Next Meeting - Regular City Council - February 25, 2026

The City of Sedro-Woolley complies with applicable Federal civil rights laws and does not discriminate on the basis of race, color, national origin, limited English proficiency, age, disability, or sex. The City of Sedro-Woolley doesn't exclude people or treat them differently because of race, color, national origin, limited English proficiency, age, disability, or sex.

The City of Sedro-Woolley also complies with applicable state laws and doesn't discriminate on the basis of creed, gender, gender expression or identity, sexual orientation, marital status, religion, honorably discharged veteran or military status, or the use of a trained dog guide or service animal by a person with a disability.

Join Zoom Meeting:

<https://zoom.us/j/91786850179?pwd=Vys0Y29XalZmQTRmemJBM2txVDIUQT09>

or dial by location at:

- +1 253 215 8782 US (Tacoma)
- +1 669 900 6833 US (San Jose)
- +1 346 248 7799 US (Houston)
- +1 929 205 6099 US (New York)
- +1 301 715 8592 US (Washington DC)
- +1 312 626 6799 US (Chicago)

Meeting ID: 917 8685 0179

Passcode: 091845

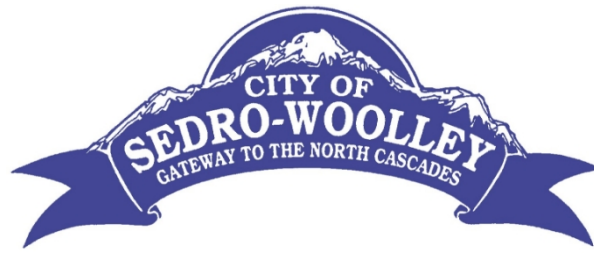

City Council Agenda Item

Agenda Item No.: e.1.

Date: February 11, 2026

From: Kelly Kohnken, Finance Director / City Clerk

Subject: Minutes - Special City Council Meeting - January 28, 2026

RECOMMENDED ACTION:

Motion to approve Special City Council meeting minutes for the special meeting held on January 28, 2026.

BACKGROUND/SUMMARY INFORMATION:

Minutes taken on January 28, 2026, for the Special City Council Meeting.

FISCAL IMPACT, IF APPROPRIATE:

None

ATTACHMENTS:

1. 2026.01.28 Special Meeting Minutes

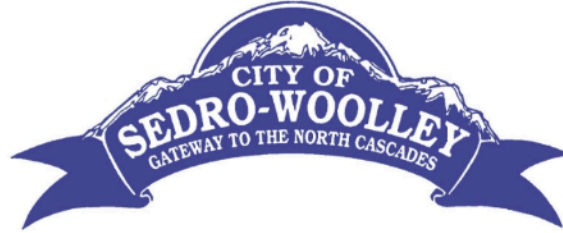

Special Meeting of the
January 28, 2026 - 4:00 PM

a. Call to Order

Mayor Julia Johnson called the meeting to order at 4:05 P.M.

b. Roll Call

Present: Mayor Julia Johnson, Councilmembers JoEllen Kesti, Paul Cocke, Kevin Loy, Nora Pederson, Allan Henderson, and Nick Lavacca.

c. Unfinished Business

d. New Business

1. City Council Goal Setting

Council along with the Mayor, City Administrator Charlie Bush, and Finance Director Kelly Kohnken discussed the city goals submitted by council members.

Council will tentatively move forward with four goals, broadly listed below. These goals will be refined by city staff and brought for further discussion at the March 2026 City Council study session.

1. Continuing with the parks and recreation focus.
2. Smart, stable growth that benefits all who call Sedro-Woolley home. Enhance the local economy, public safety, and overall well being of the City of Sedro-Woolley.
3. Traffic improvements. Improve pedestrian transportation infrastructure within the city.
4. Provide accountable leadership that is fair, accessible, and transparent both in reality and perception. Fiscal responsibility.

No action was taken.

e. Adjournment

The meeting adjourned at 5:34 P.M.

ATTEST:

APPROVED:

Clerk

Chair

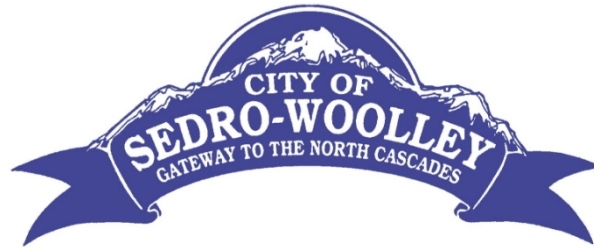

City Council Agenda Item

Agenda Item No.: e.2.

Date: February 11, 2026

From: Kelly Kohnken, Finance Director / City Clerk

Subject: Minutes - Regular City Council Meeting - January 28, 2026

RECOMMENDED ACTION:

Motion to approve City Council meeting minutes for the regular meeting held on January 28, 2026.

BACKGROUND/SUMMARY INFORMATION:

Minutes recorded from City Council Minutes held on January 28, 2026.

FISCAL IMPACT, IF APPROPRIATE:

None

ATTACHMENTS:

1. 2026.01.28 City Council Meeting Minutes

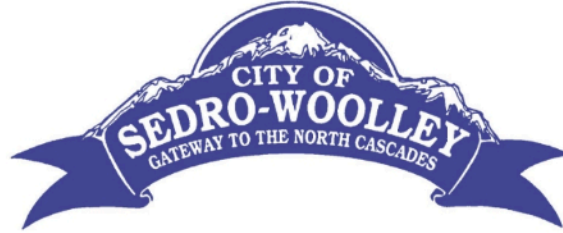

Regular Meeting of the City Council
January 28, 2026 - 6:00 PM Hybrid Meeting

a. Call to Order

Mayor Julia Johnson called the meeting to order at 6:00 P.M.

b. Pledge of Allegiance

c. Roll Call

Present: Mayor Julia Johnson, Councilmembers JoEllen Kesti, Paul Cocke, Kevin Loy, Joe Burns, Nora Pederson, Allan Henderson, and Nick Lavacca.

d. Approval of Agenda

Motion made by Councilmember Henderson and seconded by Councilmember Kesti to approve the agenda by adding item 2025-219-ILA the NorthStar, the Skagit County, Burlington, Mount Vernon and Anacortes collaborative agreement that passed on January 14, 2026, to new business for termination of the agreement. Motion carried (6-0).

e. Consent Agenda

Note: Items on the Consent Agenda are considered routine in nature and may be adopted by the Council by a single motion, unless any Councilmember wishes an item to be removed. The Council on the Regular Agenda will consider any item so removed after the Consent Agenda.

Motion made by Councilmember Henderson and seconded by Councilmember Lavacca to approve the consent agenda items number 1, 2, 3, 5, 6, and 7. Pulling item number 4 for further discussion. Motion carried (6-0).

Motion made by Councilmember Pederson and seconded by Councilmember Lavacca to approve item number 4, Resolution 1178-26, updating the 2026 non-represented salary schedule. Motion carried (6-0).

1. Minutes - City Council Study Session Meeting - January 7, 2026
2. Minutes - Regular City Council Meeting - January 14, 2026
3. Check Register - Regular and Off-Cycle
4. Resolution 1178-26 - Update 2026 Non-Represented Salary Schedule
5. Ordinance 2112-26 - 2026 Mayor Salary
6. 2026-245-IA - Fire District 8 - Interlocal Agreement Amendment Fire and Emergency Medical Services and Joint Operation of Facilities

7. Resolution 1179-26 - Sole Source - State St. Pump Station Generator Control Panel

f. Introduction of Special Guests and Presentation

1. Sedro-Woolley School District Renewal Levy Educational Programs and Operations (EPO)

Brett Greenwood, Assistant Superintendent of Sedro-Woolley School District Education Programs and Operations, shared a PowerPoint presentation regarding the renewal of the two education levies.

g. City Administrator Report

City Administrator Charlie Bush spoke with City Council regarding upcoming projects that can be accessed online on the City of Sedro-Woolley public website.

h. Councilmember and Mayor's Report

Councilmember Henderson spoke about several complaints he had received about a property on Talcott St and then shared that a citizen was pleased with our Solid Waste Recycling Center and how easy it is to bring items down to separate and drop off.

Councilmember Kesti had nothing to report.

Councilmember Pederson shared with council that she had taken a trip to Olympia to meet with some of our representatives to advocate for our city's legislative priorities. She spoke about the budget and funding regarding the wastewater treatment plant, the need for a new police station and the John Liner project.

Councilmember Pederson wanted to thank AWC for covering some of the cost of sending her to Olympia and having this opportunity.

Councilmember Cocke shared with council that he attended a Skagit Transit Board meeting and another meeting regarding the restoration of the HUB building which he found very interesting.

Councilmember Loy had nothing to report.

Councilmember Lavacca had nothing to report.

Mayor Julia Johnson had nothing to report.

i. Proclamation(s)

j. Public Comments

Please keep comments to three minutes or less. Because State law prohibits the use of city facilities for the purpose of supporting or opposing a campaign or ballot proposition, we respectfully request that public comment not make reference to such matters.

Written comments will be accepted by letter or via email at finance@sedro-woolley.gov Attn: 'Public

Comment' until 4:30pm the day before the meeting.

A public comment period was held.

Karl de Jong and Philip Murray made public comment.

k. Public Hearing(s)

l. Unfinished Business

m. New Business

1. Procedure - Filling Council Vacancy

Finance Director Kelly Kohnken shared with city council the procedures regarding filling the city council vacancy position that is in the governance handbook.

No action was taken.

2. Ordinance 2115-26 - Adopt the Comprehensive Plan - 1st Read

Community Development Director Tom Glover spoke with city council about the background and summary information regarding Ordinance 2115-26, for adopting the comprehensive plan.

No action was taken.

3. NorthStar Burlington, Mount Vernon, Sedro-Woolley, and Anacortes collaborative Interlocal Agreement 2025-219-ILA.

Motion made by Councilmember Henderson and seconded by Councilmember Kesti to terminate the NorthStar 2025-219-ILA with Skagit County, Burlington, Sedro-Woolley, Mount Vernon and Anacortes collaboration interlocal agreement. Motion carried (4-2). Councilmember Pederson and Councilmember Cocke opposed.

n. Information Only Items

1. 2025-2026 Budget Highlights - 2025 Accomplishments

Finance Director Kelly Kohnken announced a PowerPoint would be shared with the city council. Directors Bill Bullock, Tom Glover, Woody Tovar-Cano, Police Chief Dan McIlraith and Fire Chief Frank Wagner would share department accomplishments along with future and completed projects throughout Sedro-Woolley.

o. Good of the Order

Call for council members and staff to present items for discussion or for council members to make a motion to add an item to a future council agenda.

No items were discussed.

p. Executive Session

1. Discussion with Legal Counsel About Current or Potential Litigation (RCW 42.30.110(1)(i))

At 7:35pm Mayor Julia Johnson announced the city council, City Attorney and the City Administrator would be in executive session to discuss with legal counsel about potential litigation (RCW 42.30.110(1)(i)) for 15 minutes to return at 7:50pm.

At 7:49 Mayor Julia Johnson extended the executive session by 5 minutes to 7:54.

At 7:54 Mayor Julia Johnson and the city council returned.

No action was taken.

q. Adjournment

The meeting adjourned at 7:55pm.

ATTEST:

APPROVED:

Kelly Kohnken, City Clerk

Julia Johnson, Mayor

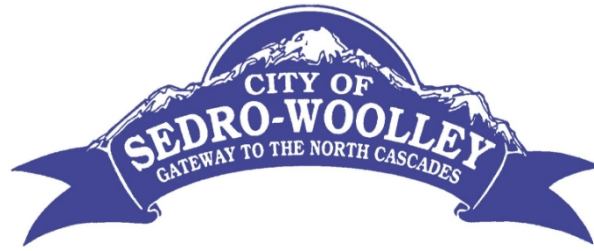

City Council Agenda Item

Agenda Item No.: e.3.

Date: February 11, 2026

From: Kelly Kohnken, Finance Director / City Clerk

Subject: Check Register - Regular

RECOMMENDED ACTION:

Motion to approve check register, EFTs, and payroll as described.

BACKGROUND/SUMMARY INFORMATION:

Claims checks #206039 through #206119, plus EFTs. Payroll ACHs including associated benefit checks #61538 through #61547.

FISCAL IMPACT, IF APPROPRIATE:

Claims checks, plus EFTs, totaling \$348,481.12

Payroll totaling \$681,007.78

ATTACHMENTS:

1. 2026.02.11 Check Register

CHECK REGISTER

City Of Sedro-Woolley

Time: 15:15:09 Date: 02/11/2026

02/11/2026 To: 02/11/2026

Page: 1

Trans	Date	Type	Acct #	Chk #	Claimant	Amount	Memo
1143	02/11/2026	Claims	2	EFT	City of Sedro-Woolley	15.65	
					101 - 576 80 47 053 - Other Utilities	15.65	
1144	02/11/2026	Claims	2	EFT	City of Sedro-Woolley	15.65	
					104 - 559 30 01 104 - Utility Payments on Redevelop	15.65	
1145	02/11/2026	Claims	2	EFT	City of Sedro-Woolley	15.65	
					104 - 595 20 63 082 - RW Trail Road Extension	15.65	
1146	02/11/2026	Claims	2	EFT	City of Sedro-Woolley	15.65	
					104 - 595 20 63 082 - RW Trail Road Extension	15.65	
1147	02/11/2026	Claims	2	EFT	City of Sedro-Woolley	101.92	
					104 - 559 30 01 105 - Utility Payment on Redevelopm	101.92	
1148	02/11/2026	Claims	2	EFT	City of Sedro-Woolley	101.92	
					101 - 576 80 47 025 - Olmsted Park	101.92	
1149	02/11/2026	Claims	2	EFT	City of Sedro-Woolley	42.43	
					001 - 558 60 49 041 - Miscellaneous - Planning And	42.43	
1150	02/11/2026	Claims	2	EFT	Comcast Holdings Corp	674.72	
					001 - 518 80 42 021 - Internet Services	674.72	
1151	02/11/2026	Claims	2	EFT	Pitney Bowes Inc	228.04	
					001 - 514 23 31 000 - Supplies	228.04	
1152	02/11/2026	Claims	2	EFT	Puget Sound Energy, Inc.	3,311.18	
					401 - 535 80 47 000 - Public Utilities	3,311.18	
1153	02/11/2026	Claims	2	EFT	Puget Sound Energy, Inc.	16,589.33	
					103 - 542 63 47 000 - Public Utilities	16,589.33	
1154	02/11/2026	Claims	2	EFT	Puget Sound Energy, Inc.	18.06	
					103 - 542 63 47 000 - Public Utilities	18.06	
1155	02/11/2026	Claims	2	EFT	Puget Sound Energy, Inc.	217.22	
					001 - 521 20 47 000 - Public Utilities	217.22	
1156	02/11/2026	Claims	2	EFT	Puget Sound Energy, Inc.	120.10	
					401 - 535 80 47 000 - Public Utilities	120.10	
1157	02/11/2026	Claims	2	EFT	Puget Sound Energy, Inc.	65.71	
					101 - 576 80 47 053 - Other Utilities	65.71	
1158	02/11/2026	Claims	2	EFT	Puget Sound Energy, Inc.	570.52	
					101 - 576 80 47 000 - Riverfront	570.52	
1159	02/11/2026	Claims	2	EFT	Puget Sound Energy, Inc.	450.61	
					101 - 576 80 47 000 - Riverfront	450.61	
1160	02/11/2026	Claims	2	EFT	Puget Sound Energy, Inc.	10.87	
					101 - 576 80 47 000 - Riverfront	10.87	
1161	02/11/2026	Claims	2	EFT	Puget Sound Energy, Inc.	114.52	
					103 - 542 63 47 000 - Public Utilities	114.52	
1162	02/11/2026	Claims	2	EFT	Puget Sound Energy, Inc.	257.69	
					101 - 576 80 47 052 - Bingham Caretaker	257.69	
1163	02/11/2026	Claims	2	EFT	Puget Sound Energy, Inc.	691.78	
					101 - 576 80 47 010 - Community Center	691.78	
1164	02/11/2026	Claims	2	EFT	Puget Sound Energy, Inc.	143.08	
					102 - 536 20 47 000 - Public Utilities	143.08	
1165	02/11/2026	Claims	2	EFT	Puget Sound Energy, Inc.	407.88	

CHECK REGISTER

City Of Sedro-Woolley

Time: 15:15:09 Date: 02/11/2026

02/11/2026 To: 02/11/2026

Page: 2

Trans	Date	Type	Acct #	Chk #	Claimant	Amount	Memo
			103 - 542 63 47 000 - Public Utilities			407.88	
1166	02/11/2026	Claims	2	EFT	Puget Sound Energy, Inc.	693.12	
			103 - 542 63 47 000 - Public Utilities			693.12	
1167	02/11/2026	Claims	2	EFT	Puget Sound Energy, Inc.	202.57	
			401 - 535 80 47 000 - Public Utilities			202.57	
1168	02/11/2026	Claims	2	EFT	Puget Sound Energy, Inc.	10.87	
			101 - 576 80 47 053 - Other Utilities			10.87	
1169	02/11/2026	Claims	2	EFT	Puget Sound Energy, Inc.	31.78	
			425 - 531 50 47 000 - Public Utilities			31.78	
1170	02/11/2026	Claims	2	EFT	Puget Sound Energy, Inc.	63.07	
			101 - 576 80 47 040 - Train			63.07	
1171	02/11/2026	Claims	2	EFT	Puget Sound Energy, Inc.	225.09	
			412 - 537 80 47 000 - Public Utilities			225.09	
1172	02/11/2026	Claims	2	EFT	Puget Sound Energy, Inc.	17,998.70	
			401 - 535 80 47 000 - Public Utilities			17,998.70	
1173	02/11/2026	Claims	2	EFT	Puget Sound Energy, Inc.	13.70	
			101 - 576 80 47 000 - Riverfront			13.70	
1174	02/11/2026	Claims	2	EFT	Puget Sound Energy, Inc.	190.47	
			401 - 535 80 47 000 - Public Utilities			190.47	
1175	02/11/2026	Claims	2	EFT	Puget Sound Energy, Inc.	610.00	
			401 - 535 80 47 000 - Public Utilities			610.00	
1176	02/11/2026	Claims	2	EFT	Puget Sound Energy, Inc.	199.37	
			425 - 531 50 47 000 - Public Utilities			199.37	
1177	02/11/2026	Claims	2	EFT	Puget Sound Energy, Inc.	95.78	
			101 - 576 80 47 030 - Museum Apartments			95.78	
1178	02/11/2026	Claims	2	EFT	Puget Sound Energy, Inc.	10.84	
			101 - 576 80 47 030 - Museum Apartments			10.84	
1179	02/11/2026	Claims	2	EFT	Puget Sound Energy, Inc.	172.03	
			401 - 535 80 47 000 - Public Utilities			172.03	
1180	02/11/2026	Claims	2	EFT	Puget Sound Energy, Inc.	35.90	
			101 - 576 80 47 030 - Museum Apartments			35.90	
1181	02/11/2026	Claims	2	EFT	Puget Sound Energy, Inc.	288.15	
			101 - 576 80 47 050 - Hammer Square			288.15	
1182	02/11/2026	Claims	2	EFT	Puget Sound Energy, Inc.	4,214.14	
			101 - 576 80 47 070 - City Hall			4,214.14	
1183	02/11/2026	Claims	2	EFT	Puget Sound Energy, Inc.	101.58	
			401 - 535 80 47 000 - Public Utilities			101.58	
1184	02/11/2026	Claims	2	EFT	Puget Sound Energy, Inc.	617.75	
			101 - 576 80 47 020 - Senior Center			617.75	
1185	02/11/2026	Claims	2	EFT	Puget Sound Energy, Inc.	373.55	
			401 - 535 80 47 000 - Public Utilities			373.55	
1186	02/11/2026	Claims	2	EFT	Puget Sound Energy, Inc.	274.07	
			401 - 535 80 47 000 - Public Utilities			274.07	
1187	02/11/2026	Claims	2	EFT	Puget Sound Energy, Inc.	392.29	
			401 - 535 80 47 000 - Public Utilities			392.29	

CHECK REGISTER

City Of Sedro-Woolley

Time: 15:15:09 Date: 02/11/2026

02/11/2026 To: 02/11/2026

Page: 3

Trans	Date	Type	Acct #	Chk #	Claimant	Amount	Memo
1188	02/11/2026	Claims	2	EFT	Puget Sound Energy, Inc.	63.45	
					001 - 521 20 47 000 - Public Utilities	63.45	
1189	02/11/2026	Claims	2	EFT	Puget Sound Energy, Inc.	996.04	
					001 - 522 50 47 000 - Public Utilities	996.04	
1190	02/11/2026	Claims	2	EFT	Puget Sound Energy, Inc.	152.91	
					101 - 576 80 47 051 - Bingham / Memorial	152.91	
1191	02/11/2026	Claims	2	EFT	Puget Sound Energy, Inc.	48.60	
					104 - 559 30 01 105 - Utility Payment on Redevelopm	48.60	
1192	02/11/2026	Claims	2	EFT	Puget Sound Energy, Inc.	550.87	
					101 - 576 80 47 051 - Bingham / Memorial	550.87	
1193	02/11/2026	Claims	2	EFT	Skagit PUD	91.63	
					401 - 535 80 47 000 - Public Utilities	91.63	
1194	02/11/2026	Claims	2	EFT	Skagit PUD	91.63	
					401 - 535 80 47 000 - Public Utilities	91.63	
1195	02/11/2026	Claims	2	EFT	United Parcel Service, Inc.	30.52	
					001 - 522 20 42 010 - Postage	30.52	
1196	02/11/2026	Claims	2	EFT	United Parcel Service, Inc.	21.59	
					001 - 522 20 42 010 - Postage	21.59	
1197	02/11/2026	Claims	2	EFT	Cellco Partnership dba Verizon Wireless	4,356.51	
					001 - 513 10 42 020 - Telephone	211.69	
					001 - 514 23 42 020 - Telephone	107.44	
					001 - 518 80 42 020 - Telephone	107.44	
					001 - 521 20 42 020 - Telephone	1,891.74	
					001 - 524 20 42 020 - Telephone	107.44	
					401 - 535 80 42 030 - Cell Phones	448.67	
					102 - 536 20 42 020 - Telephone	108.21	
					412 - 537 80 42 025 - Cell Phones	435.94	
					103 - 542 30 42 020 - Telephone	290.17	
					001 - 558 60 42 020 - Telephone	68.20	
					101 - 576 80 42 020 - Telephone	354.41	
					001 - 595 10 42 025 - Cell Phones	225.16	
1198	02/11/2026	Claims	2	EFT	Cellco Partnership dba Verizon Wireless	586.02	
					001 - 521 20 42 020 - Telephone	440.19	
					001 - 522 20 42 020 - Telephone	65.81	
					101 - 576 80 42 020 - Telephone	40.01	
					001 - 595 10 42 025 - Cell Phones	40.01	
1199	02/11/2026	Claims	2	EFT	WA St Dept of Revenue	24,480.08	
					425 - 531 50 44 000 - Taxes & Assessments	1,494.16	
					401 - 535 80 44 010 - Taxes & Assessments	8,698.66	
					102 - 536 20 44 010 - Taxes And Assessments	139.80	
					106 - 536 30 44 010 - Taxes and Assessments	1.75	
					412 - 537 80 44 001 - Taxes & Assessments	13,960.19	
					101 - 576 80 44 010 - Taxes And Assessments	69.42	
					102 - 589 30 11 102 - DO NOT USE - Sales Tax Remit	116.10	
1200	02/11/2026	Claims	2	EFT	WEX Bank	10,665.11	
					001 - 518 20 32 000 - Auto Fuel	211.39	
					001 - 521 20 32 000 - Auto Fuel	5,762.48	
					001 - 522 20 32 000 - Auto Fuel/Diesel	3,077.23	
					425 - 531 50 32 000 - Vehicle Fuel	103.19	
					401 - 535 80 32 000 - Auto Fuel/Diesel	145.94	
					102 - 536 20 32 000 - Auto Fuel/Diesel	171.37	

CHECK REGISTER

City Of Sedro-Woolley

Time: 15:15:09 Date: 02/11/2026

02/11/2026 To: 02/11/2026

Page: 4

Trans	Date	Type	Acct #	Chk #	Claimant	Amount	Memo
			102 - 536 20 32 001		- Propane	116.99	
			412 - 537 80 32 000		- Auto Fuel/Diesel	259.56	
			103 - 542 30 32 000		- Auto Fuel/Diesel	342.71	
			101 - 576 80 32 000		- Auto Fuel/Diesel	474.25	
1201	02/11/2026	Claims	2	EFT	NW Fiber LLC, dba Ziplly Fiber	236.30	
			001 - 518 80 42 021		- Internet Services	236.30	
1202	02/11/2026	Claims	2	EFT	NW Fiber LLC, dba Ziplly Fiber	900.98	
			001 - 512 50 42 020		- Telephone	54.06	
			001 - 513 10 42 020		- Telephone	81.09	
			001 - 514 23 42 020		- Telephone	81.09	
			001 - 515 31 42 001		- Telephone	36.04	
			001 - 518 80 42 020		- Telephone	27.03	
			001 - 521 20 42 020		- Telephone	270.29	
			001 - 522 20 42 020		- Telephone	99.11	
			001 - 524 20 42 020		- Telephone	27.03	
			401 - 535 80 42 020		- Telephone	72.07	
			412 - 537 80 42 020		- Telephone	36.04	
			103 - 542 30 42 020		- Telephone	9.01	
			001 - 558 60 42 020		- Telephone	27.03	
			101 - 576 80 42 020		- Telephone	18.02	
			001 - 595 10 42 020		- Telephone	63.07	
1203	02/11/2026	Claims	2	EFT	NW Fiber LLC, dba Ziplly Fiber	481.22	
			401 - 535 80 42 020		- Telephone	481.22	
1204	02/11/2026	Claims	2	206039	C/O Instrument Technologi Accredited Labs	537.50	
			401 - 535 50 48 000		- Maintenance Contracts	537.50	
1205	02/11/2026	Claims	2	206040	Amazon Capital Svcs, Inc	2,193.41	
			001 - 514 23 31 000		- Supplies	127.03	
			001 - 514 23 31 000		- Supplies	62.93	
			001 - 514 23 31 000		- Supplies	10.63	
			001 - 514 23 31 000		- Supplies	211.60	
			001 - 521 20 26 000		- Uniforms/Accessories	445.18	
			001 - 521 20 26 000		- Uniforms/Accessories	137.95	
			001 - 521 20 26 000		- Uniforms/Accessories	-128.09	
			001 - 521 20 26 000		- Uniforms/Accessories	-37.96	
			001 - 521 20 31 002		- Office/Operating Supplies	15.94	
			001 - 521 20 31 002		- Office/Operating Supplies	529.26	
			001 - 521 20 31 002		- Office/Operating Supplies	22.38	
			001 - 521 20 31 002		- Office/Operating Supplies	81.02	
			001 - 521 20 31 002		- Office/Operating Supplies	9.24	
			001 - 521 20 31 002		- Office/Operating Supplies	35.36	
			001 - 521 20 41 023		- Canine	57.74	
			001 - 522 21 35 000		- Small Tools & Minor Equipmer	55.65	
			001 - 524 20 31 000		- Off/Oper Supps & Books	9.84	
			401 - 535 80 31 000		- Office Supplies	149.49	
			401 - 535 80 31 000		- Office Supplies	14.10	
			401 - 535 80 31 020		- Op Supplies-Chemicals	187.87	
			103 - 542 30 35 000		- Small Tools/Minor Equip	152.16	
			001 - 558 60 31 000		- Supplies/Books	9.84	
			101 - 576 80 31 025		- Operating Sup - Olmsted Park	24.42	
			001 - 595 10 31 000		- Supplies	9.83	
1206	02/11/2026	Claims	2	206041	C/O Bonnie Thompson BYK Construction	200.00	
			001 - 322 10 01 000		- Planning Permits	-200.00	
1207	02/11/2026	Claims	2	206042	Beaver Lake Quarry	2,244.71	
			001 - 525 30 41 000		- Disaster Recovery - Other Expre	2,244.71	
1208	02/11/2026	Claims	2	206043	Teri Bever	100.00	

CHECK REGISTER

City Of Sedro-Woolley

Time: 15:15:09 Date: 02/11/2026

02/11/2026 To: 02/11/2026

Page: 5

Trans	Date	Type	Acct #	Chk #	Claimant	Amount	Memo
			631 - 389 90 03 631		- Unapplied Park and Facility Res	-100.00	
1209	02/11/2026	Claims	2	206044	Jana R. Bouzek	681.25	
			001 - 521 20 41 001		Professional Services	681.25	
1210	02/11/2026	Claims	2	206045	C.Hlth130, dba Cardinal Health 112 LLC	20.02	
			001 - 522 21 31 000		Operating Supplies - Medical	20.02	
1211	02/11/2026	Claims	2	206046	Central Welding Supply	120.80	
			001 - 522 21 31 000		Operating Supplies - Medical	120.80	
1212	02/11/2026	Claims	2	206047	Kenneth & Charles Spear	2,019.00	
			401 - 535 50 48 050		Maint Of General Equip	1,429.00	
			103 - 542 30 48 010		Repair/Maintenance-Equip	590.00	
1213	02/11/2026	Claims	2	206048	Dell Marketing LP	9,554.61	
			501 - 594 21 64 501		Equip & Vehicles - Police	9,554.61	
1214	02/11/2026	Claims	2	206049	Gregory Dixon	900.00	
			001 - 515 93 41 001		Indigent Defense Conflict Cour	900.00	
1215	02/11/2026	Claims	2	206050	Dobbs Heavy Duty Holdings, LLC	2,405.36	
			412 - 537 50 48 000		Repairs/maint-equip	296.68	
			412 - 537 50 48 000		Repairs/maint-equip	408.00	
			412 - 537 50 48 000		Repairs/maint-equip	101.20	
			412 - 537 50 48 000		Repairs/maint-equip	95.01	
			412 - 537 50 48 000		Repairs/maint-equip	-123.45	
			501 - 548 30 31 000		Operating Supplies	1,627.92	
1216	02/11/2026	Claims	2	206051	E & E Lumber, Inc.	1,749.39	
			401 - 535 50 48 050		Maint Of General Equip	56.53	
			102 - 536 20 48 040		Repair/Maint-Equip & Bldg	7.29	
			103 - 542 30 31 000		Operating Supplies	14.04	
			103 - 542 30 31 000		Operating Supplies	203.27	
			103 - 542 30 31 000		Operating Supplies	66.24	
			103 - 542 30 31 000		Operating Supplies	28.08	
			103 - 542 30 31 000		Operating Supplies	47.76	
			103 - 542 30 31 000		Operating Supplies	58.10	
			103 - 542 30 31 000		Operating Supplies	92.34	
			101 - 576 80 31 001		Operating Sup - Riverfront	23.37	
			101 - 576 80 48 001		Riverfront	8.33	
			101 - 576 80 48 001		Riverfront	-3.65	
			101 - 576 80 48 001		Riverfront	156.34	
			101 - 576 80 48 005		Senior Center	513.69	
			101 - 576 80 48 016		City Hall	477.66	
1217	02/11/2026	Claims	2	206052	Mark Edick	294.42	
			425 - 343 10 00 000		Stormwater Fees	-35.05	
			401 - 343 50 00 000		Sewer Service Charges	-193.25	
			412 - 343 74 00 000		Equipment Rental	-66.12	
1218	02/11/2026	Claims	2	206053	Enviro-Clean Equip, Inc.	3,846.78	
			425 - 531 50 31 000		Operating Supplies	3,846.78	
1219	02/11/2026	Claims	2	206054	Ewing Irrigation Prod Inc.	6,386.73	
			101 - 576 80 48 001		Riverfront	4,000.00	
			101 - 576 80 48 013		Tesarik Park	2,386.73	
1220	02/11/2026	Claims	2	206055	Family Promise of Skagit Valley	4,733.95	
			116 - 551 00 00 116		Public Housing Services	1,000.00	
			117 - 551 00 00 117		Affordable Housing - Operatio	3,733.95	
1221	02/11/2026	Claims	2	206056	Ferguson US Holdings, Inc	206.39	
			401 - 535 50 48 050		Maint Of General Equip	206.39	

CHECK REGISTER

City Of Sedro-Woolley

Time: 15:15:09 Date: 02/11/2026

02/11/2026 To: 02/11/2026

Page: 6

Trans	Date	Type	Acct #	Chk #	Claimant	Amount	Memo
1222	02/11/2026	Claims	2	206057	FirstNET/AT&T Mobility	825.42	
					001 - 522 20 42 020 - Telephone	758.57	
					401 - 535 80 41 000 - Professional Services	66.85	
1223	02/11/2026	Claims	2	206058	Keith Ford	249.80	
					001 - 522 20 41 010 - Prof Service-Medical Exams	249.80	
1224	02/11/2026	Claims	2	206059	Galls, LLC	1,181.98	
					001 - 522 20 26 000 - Uniforms	382.44	
					001 - 522 20 26 000 - Uniforms	545.13	
					001 - 522 20 26 000 - Uniforms	127.48	
					001 - 522 20 26 000 - Uniforms	126.93	
1225	02/11/2026	Claims	2	206060	Genuine Parts Co. Inc	136.94	
					401 - 535 50 48 040 - Maintenance Of Vehicles	24.27	
					103 - 542 30 31 000 - Operating Supplies	-48.77	
					101 - 576 80 48 021 - Equipment	161.44	
1226	02/11/2026	Claims	2	206061	Richard Lance George	2,220.00	
					001 - 521 20 27 000 - Retired Medical	2,220.00	
1227	02/11/2026	Claims	2	206062	Gordon Truck Centers, Inc	2,169.11	
					412 - 537 50 48 000 - Repairs/maint-equip	1,012.29	
					412 - 537 50 48 000 - Repairs/maint-equip	558.13	
					412 - 537 50 48 000 - Repairs/maint-equip	598.69	
1228	02/11/2026	Claims	2	206063	Guardian Security Systems, Inc.	1,333.21	
					101 - 576 80 48 005 - Senior Center	1,333.21	
1229	02/11/2026	Claims	2	206064	Judy Hall	100.00	
					631 - 389 90 03 631 - Unapplied Park and Facility Res	-100.00	
1230	02/11/2026	Claims	2	206065	Heritage Bank	617.61	
					104 - 595 30 63 083 - Const-SR 9-John Liner-McGariç	617.61	
1231	02/11/2026	Claims	2	206066	Home Depot Credit Services	341.19	
					101 - 576 80 48 016 - City Hall	295.50	
					101 - 576 80 48 016 - City Hall	74.07	
					101 - 576 80 48 016 - City Hall	47.82	
					101 - 576 80 48 016 - City Hall	-76.20	
1232	02/11/2026	Claims	2	206067	ICONIX Waterworks (US) Inc	3,153.09	
					401 - 535 50 48 010 - Maintenance Of Lines	2,037.96	
					401 - 535 50 48 010 - Maintenance Of Lines	1,115.13	
1233	02/11/2026	Claims	2	206068	Brandy Jensen	32.29	
					001 - 513 10 49 010 - Dues & Subscriptions	32.29	
1234	02/11/2026	Claims	2	206069	Kelley Create	808.28	
					001 - 591 80 70 517 - Leases + Subscription IT (SBIT)	808.28	
1235	02/11/2026	Claims	2	206070	LTI, Inc.	6,731.86	
					103 - 542 66 31 000 - Operating Supplies	6,731.86	
1236	02/11/2026	Claims	2	206071	Language Exchange, Inc	1,210.96	
					001 - 512 50 41 040 - Language Interpreter	1,210.96	
1237	02/11/2026	Claims	2	206072	Les Schwab Tire Center	79.27	
					412 - 537 50 48 000 - Repairs/maint-equip	79.27	
1238	02/11/2026	Claims	2	206073	Life Assist Inc.	680.16	
					001 - 522 21 31 000 - Operating Supplies - Medical	293.76	
					001 - 522 21 31 000 - Operating Supplies - Medical	386.40	
1239	02/11/2026	Claims	2	206074	Mark Christ, Architect	450.00	
					101 - 594 76 63 025 - Olmsted Park	450.00	

CHECK REGISTER

City Of Sedro-Woolley

Time: 15:15:09 Date: 02/11/2026

02/11/2026 To: 02/11/2026

Page: 7

Trans	Date	Type	Acct #	Chk #	Claimant	Amount	Memo
1240	02/11/2026	Claims	2	206075	McCaffrey Dragonflight Drones, LLC	3,382.50	
					001 - 595 10 41 000 - Professional Services	3,382.50	
1241	02/11/2026	Claims	2	206076	Walter E Nelson Co. of N. WA	1,359.47	
					103 - 542 30 31 000 - Operating Supplies	89.16	
					101 - 576 80 31 001 - Operating Sup - Riverfront	1,253.98	
					101 - 576 80 31 006 - Operating Sup - City Hall	16.33	
1242	02/11/2026	Claims	2	206077	NCL of Wisconsin, Inc.	4,389.26	
					401 - 594 35 64 001 - Portable Equipment	4,389.26	
1243	02/11/2026	Claims	2	206078	Nelson Dist, Inc. Nelson-Reisner	1,639.43	
					412 - 537 80 31 000 - Operating Supplies	288.01	
					501 - 548 30 31 000 - Operating Supplies	550.16	
					501 - 548 30 31 000 - Operating Supplies	801.26	
1244	02/11/2026	Claims	2	206079	Newman Signs Inc	1,995.10	
					103 - 542 64 31 004 - Street Sign Materials	1,995.10	
1245	02/11/2026	Claims	2	206080	North County Public Defense	23,394.28	
					001 - 515 93 41 000 - Indigent Defender	23,394.28	
1246	02/11/2026	Claims	2	206081	Northwest Biosolids	688.42	
					401 - 535 80 49 010 - Misc-Dues/Subscriptions	688.42	
1247	02/11/2026	Claims	2	206082	Oliver-Hammer, Inc	1,471.23	
					412 - 537 80 31 000 - Operating Supplies	146.59	
					412 - 537 80 31 000 - Operating Supplies	380.01	
					412 - 537 80 31 000 - Operating Supplies	515.72	
					412 - 537 80 31 000 - Operating Supplies	168.31	
					103 - 542 30 35 010 - Safety Equipment	260.60	
1248	02/11/2026	Claims	2	206083	Jorge Ortiz	100.00	
					631 - 389 90 03 631 - Unapplied Park and Facility Res	-100.00	
1249	02/11/2026	Claims	2	206084	Proforce Marketing, Inc	743.57	
					001 - 521 20 31 015 - Ammunition	743.57	
1250	02/11/2026	Claims	2	206085	Pye-Barker Fire & Safety, LLC	358.38	
					101 - 576 80 48 000 - Repairs/Maintenance	358.38	
1251	02/11/2026	Claims	2	206086	QCC Quality Controls Corp.	11,984.80	
					401 - 535 80 41 000 - Professional Services	9,937.00	
					401 - 535 80 41 000 - Professional Services	2,047.80	
1252	02/11/2026	Claims	2	206087	Ricoh USA, Inc	57.24	
					103 - 542 30 31 000 - Operating Supplies	57.24	
1253	02/11/2026	Claims	2	206088	Kevin Rogerson	400.00	
					001 - 512 50 41 000 - Professional Services	100.00	
					001 - 512 50 41 000 - Professional Services	100.00	
					001 - 512 50 41 000 - Professional Services	200.00	
1254	02/11/2026	Claims	2	206089	Heather Romano	787.50	
					001 - 521 20 41 001 - Professional Services	567.00	
					001 - 521 20 41 001 - Professional Services	220.50	
1255	02/11/2026	Claims	2	206090	SBA Structures, LLC	671.74	
					001 - 591 28 70 001 - Lease + Subscription IT (SBITA)	335.87	
					401 - 591 28 70 401 - Leases + Subscription IT (SBITA)	335.87	
1256	02/11/2026	Claims	2	206091	SRV Construction Inc	11,734.62	
					104 - 595 30 63 083 - Const-SR 9-John Liner-McGaric	11,734.62	
1257	02/11/2026	Claims	2	206092	SWS Equipment, Inc.	1,389.28	

CHECK REGISTER

City Of Sedro-Woolley

Time: 15:15:09 Date: 02/11/2026

02/11/2026 To: 02/11/2026

Page: 8

Trans	Date	Type	Acct #	Chk #	Claimant	Amount	Memo
			412 - 537 50 48 000		Repairs/maint-equip	1,389.28	
1258	02/11/2026	Claims	2	206093	Douglas Salyer	2,220.00	
			001 - 521 20 27 000		Retired Medical	2,220.00	
1259	02/11/2026	Claims	2	206094	Sedgwick Claims	4,274.65	
			001 - 511 60 21 001		Industrial Insurance	3.10	
			001 - 512 50 21 001		Industrial Insurance	3.83	
			001 - 513 10 21 001		Industrial Insurance	7.29	
			001 - 514 23 21 001		Industrial Insurance	30.99	
			001 - 518 80 21 001		Industrial Insurance	10.39	
			001 - 521 10 21 001		Industrial Insurance	78.75	
			001 - 521 20 21 001		Industrial Insurance	1,051.79	
			001 - 522 20 21 001		Industrial Insurance	741.90	
			001 - 522 21 21 001		Industrial Insurance	705.44	
			001 - 522 22 21 001		Industrial Insurance	109.37	
			001 - 522 23 21 001		Industrial Insurance	565.47	
			001 - 524 20 21 001		Industrial Insurance	36.45	
			425 - 531 50 21 001		Industrial Insurance	92.97	
			401 - 535 80 21 001		Industrial Insurance	216.92	
			102 - 536 20 21 001		Industrial Insurance	34.63	
			412 - 537 80 21 001		Industrial Insurance	215.10	
			103 - 542 30 21 001		Industrial Insurance	98.43	
			501 - 548 30 21 001		Industrial Insurance	45.43	
			001 - 558 60 21 001		Industrial Insurance	9.11	
			101 - 576 80 21 001		Industrial Insurance	138.54	
			001 - 595 10 21 001		Industrial Insurance	78.75	
1260	02/11/2026	Claims	2	206095	Sedro-Woolley Auto Parts Inc	1,005.44	
			001 - 518 20 48 000		Repair & Maintenance	161.17	
			001 - 518 20 48 000		Repair & Maintenance	-182.89	
			001 - 522 20 48 000		Repairs/Maint-Equip	185.32	
			412 - 537 50 48 000		Repairs/maint-equip	215.29	
			501 - 548 30 31 000		Operating Supplies	64.43	
			101 - 576 80 48 021		Equipment	253.47	
			101 - 576 80 48 021		Equipment	275.55	
			101 - 576 80 48 021		Equipment	274.45	
			101 - 576 80 48 021		Equipment	-241.35	
1261	02/11/2026	Claims	2	206096	Sedro-Woolley Automotive	1,805.42	
			001 - 521 20 48 010		Repair & Maint - Auto	1,017.91	
			001 - 521 20 48 010		Repair & Maint - Auto	344.06	
			001 - 521 20 48 010		Repair & Maint - Auto	356.35	
			001 - 521 20 48 010		Repair & Maint - Auto	87.10	
1262	02/11/2026	Claims	2	206097	Skagit Canine Club LLC	360.00	
			001 - 521 20 49 010		Dues/Subscriptions	360.00	
1263	02/11/2026	Claims	2	206098	Skagit Cnty Auditor	11,754.92	
			001 - 514 90 41 000		Voter Registration Costs	11,754.92	
1264	02/11/2026	Claims	2	206099	Skagit Cnty Central Svcs	4,446.65	
			001 - 521 20 41 050		Spillman System	4,446.65	
1265	02/11/2026	Claims	2	206100	Skagit Cnty Planning & Dev. Svc.	1,639.38	
			102 - 594 36 61 050		Northern State Cemetery Capit	1,639.38	
1266	02/11/2026	Claims	2	206101	Skagit Cnty Public Works	6,969.21	
			425 - 531 50 41 002		Contracted Services	6,534.99	
			103 - 542 64 31 004		Street Sign Materials	248.12	
			001 - 595 10 31 001		Address & Street Signs-Reimb	186.10	
1267	02/11/2026	Claims	2	206102	Skagit Cnty Treasurer	60,016.27	
			114 - 523 60 41 022		Jail Sales Tax Pass Through 2/1	59,016.27	

CHECK REGISTER

City Of Sedro-Woolley

Time: 15:15:09 Date: 02/11/2026

02/11/2026 To: 02/11/2026

Page: 9

Trans	Date	Type	Acct #	Chk #	Claimant	Amount	Memo
			114 - 523 60 41 022		Jail Sales Tax Pass Through 2/1	1,000.00	
1268	02/11/2026	Claims	2	206103	PNG Media LLC, dba Skagit Publishing	1,027.58	
			001 - 511 60 31 001		Legal Publications	188.30	
			001 - 511 60 31 001		Legal Publications	150.64	
			001 - 511 60 31 001		Legal Publications	182.92	
			001 - 511 60 31 001		Legal Publications	161.40	
			001 - 511 60 31 001		Legal Publications	53.80	
			001 - 511 60 31 001		Legal Publications	161.40	
			001 - 511 60 31 001		Legal Publications	59.18	
			001 - 511 60 31 001		Legal Publications	69.94	
1269	02/11/2026	Claims	2	206104	Skagit Regional Health	330.00	
			412 - 537 80 31 000		Operating Supplies	220.00	
			103 - 542 30 49 040		CDL Endorcement Fees	110.00	
1270	02/11/2026	Claims	2	206105	Stericycle	10.36	
			001 - 521 20 41 001		Professional Services	10.36	
1271	02/11/2026	Claims	2	206106	Sterling Vet Clinic	316.69	
			001 - 521 20 41 023		Canine	316.69	
1272	02/11/2026	Claims	2	206107	Suburban Propane, LP	48.87	
			102 - 536 20 32 001		Propane	48.87	
1273	02/11/2026	Claims	2	206108	Paul Taylor	4,863.60	
			001 - 521 20 27 000		Retired Medical	4,863.60	
1274	02/11/2026	Claims	2	206109	Topcon Solutions Inc	1,798.42	
			001 - 591 10 70 520		Leases + Subscription IT (SBITA	1,798.42	
1275	02/11/2026	Claims	2	206110	Univar Solutions USA LLC	1,684.39	
			401 - 535 80 31 020		Op Supplies-Chemicals	1,684.39	
1276	02/11/2026	Claims	2	206111	Vestis	44.34	
			401 - 535 80 49 000		Laundry	8.41	
			401 - 535 80 49 000		Laundry	8.41	
			412 - 537 80 49 000		Misc-Laundry	8.91	
			412 - 537 80 49 000		Misc-Laundry	8.91	
			103 - 542 30 49 000		Misc-Laundry	4.85	
			103 - 542 30 49 000		Misc-Laundry	4.85	
1277	02/11/2026	Claims	2	206112	WA Assoc Of Sheriffs &	320.00	
			001 - 521 20 49 010		Dues/Subscriptions	75.00	
			001 - 521 20 49 010		Dues/Subscriptions	245.00	
1278	02/11/2026	Claims	2	206113	WA St Patrol	166.00	
			001 - 521 20 41 040		Intergov Svc-Gun Permits	144.00	
			001 - 521 20 41 040		Intergov Svc-Gun Permits	22.00	
1279	02/11/2026	Claims	2	206114	WW Grainger Inc	203.58	
			401 - 535 80 35 000		Small Tools & Minor Equip	203.58	
1280	02/11/2026	Claims	2	206115	Western Refinery Services, Inc.	2,402.41	
			505 - 594 48 60 021		Const - PW Veh Storage Bldg	2,402.41	
1281	02/11/2026	Claims	2	206116	Whatcom Electric Company Inc.	459.33	
			501 - 548 30 31 000		Operating Supplies	459.33	
1282	02/11/2026	Claims	2	206117	Witmer Public Safety Group Inc.	274.70	
			001 - 522 20 35 000		Small Tools & Minor Equip	274.70	
1283	02/11/2026	Claims	2	206118	World Kinect Energy Services	8,653.14	
			425 - 531 50 32 000		Vehicle Fuel	205.61	
			425 - 531 50 32 000		Vehicle Fuel	189.02	
			425 - 531 50 32 000		Vehicle Fuel	213.69	

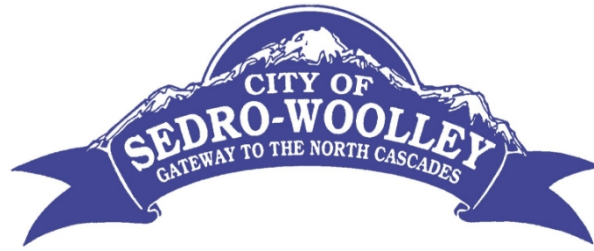

City Council Agenda Item

Agenda Item No.: f.1.

Date: February 11, 2026

From: Julia Johnson, Mayor

Subject: Central Skagit Library Director Dan Owens and Board of Trustees Chair Heather Swenson

RECOMMENDED ACTION:

Information item, no recommended action.

BACKGROUND/SUMMARY INFORMATION:

Central Skagit Library Director Dan Owens and Board of Trustees Chair Heather Swenson will provide an update on the Central Skagit Library's 2025 activities, along with background regarding the history of the library districts and plans for 2026 and beyond.

FISCAL IMPACT, IF APPROPRIATE:

ATTACHMENTS:

1. CentralSkagitLibrary_S-WCity Council 2026-2-11

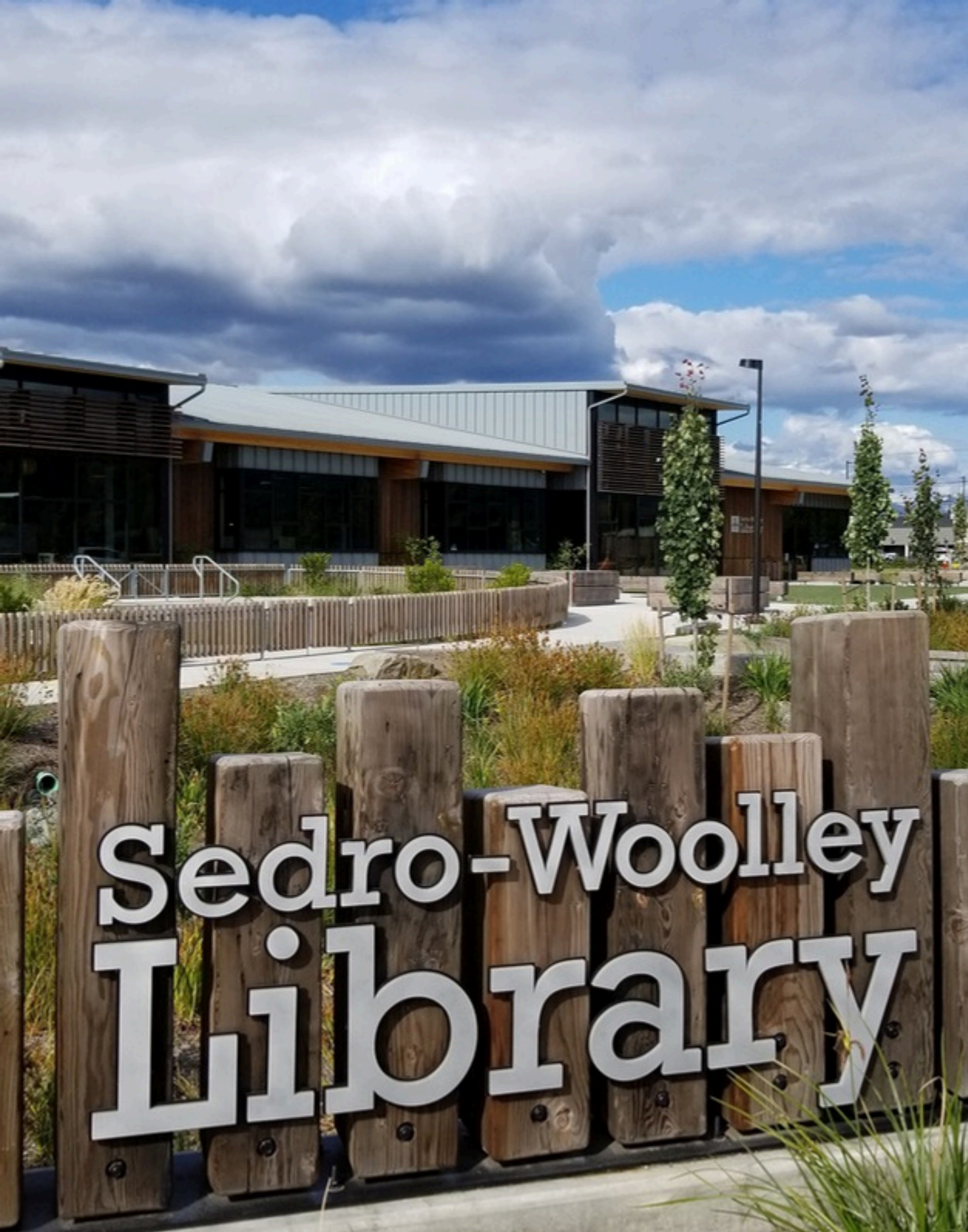

Sedro-Woolley City Council

February 11, 2026



History

2012 - Library district formation

2013 - First staff member hired

2015 - Jeanne Williams hired

2017 - Sedro-Woolley partnership agreement

2018 - District begins operating S-W library

2021 - New library opens

Board of Trustees 2026

Heather Swenson, Chair

Darcy Resetar, Vice Chair

Tim Howland

Jennifer Bunke

Leah Brooks

Service area population and library accounts

31,420 service area population

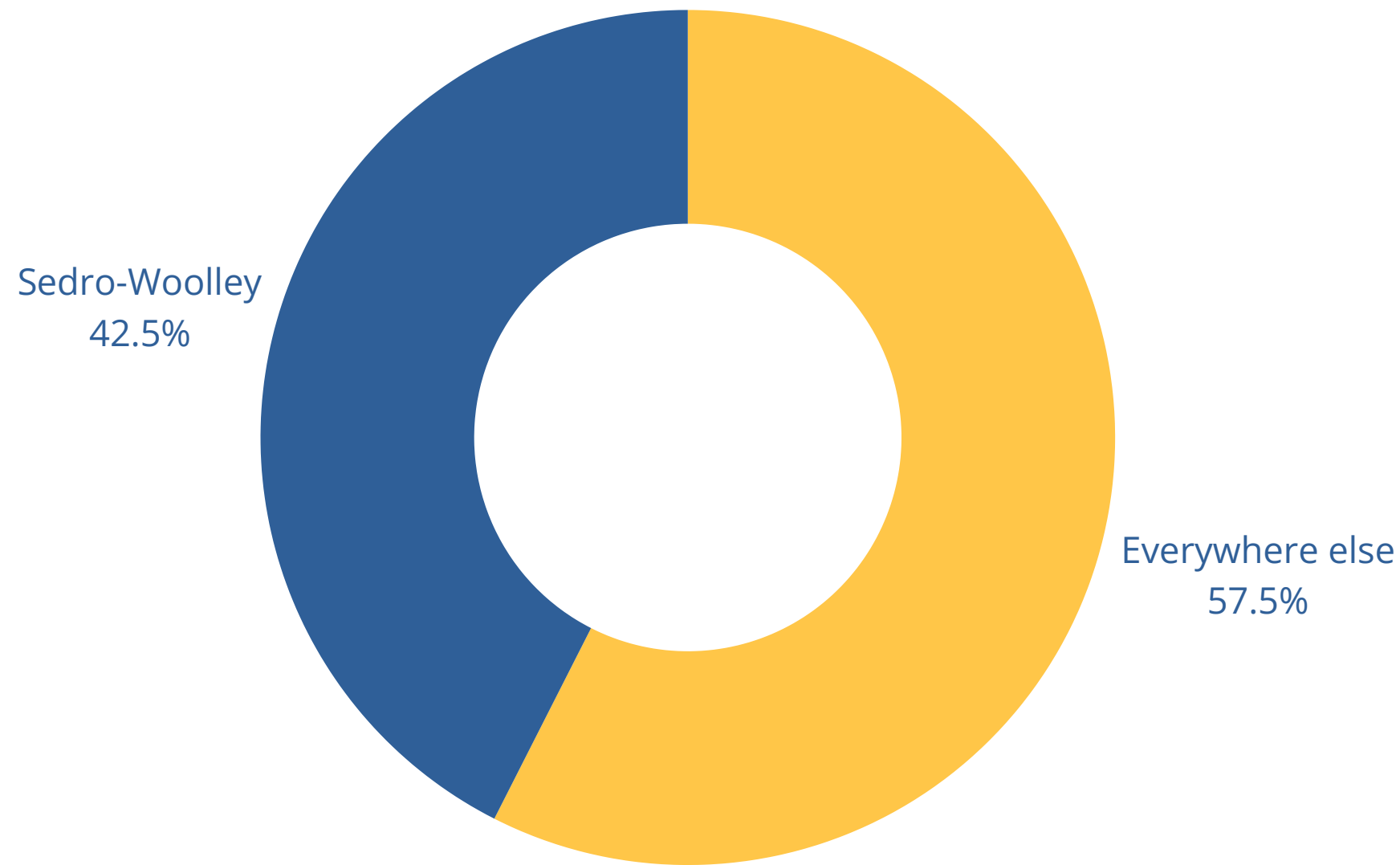

11,442 total library accounts

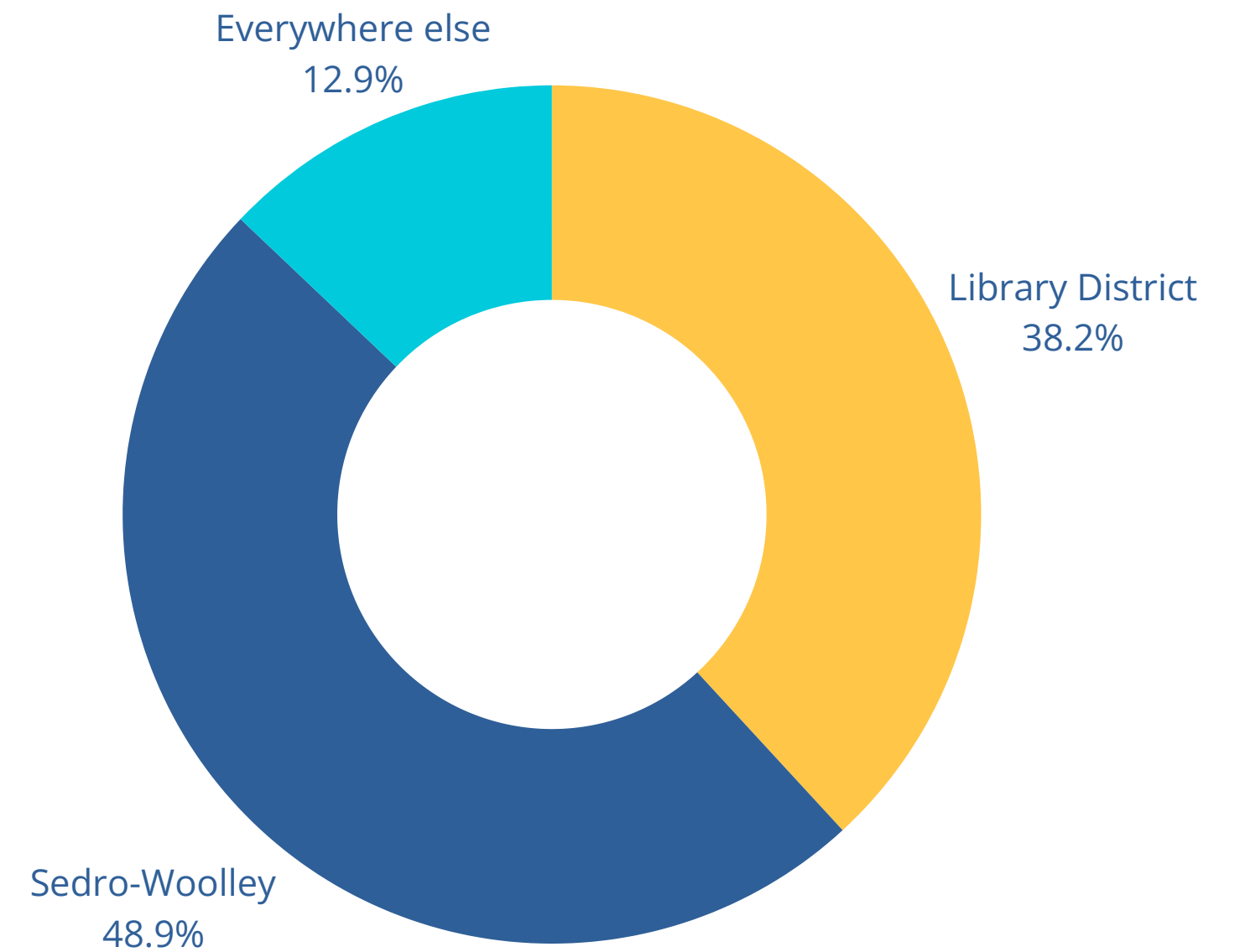

Operating Expenses 2025

Wages- \$593,024

Benefits- \$332,021

Library materials- \$167,969

Professional services - \$123,749

Supplies - \$72,563

Utilities - \$32,958

Everything else- \$34,482

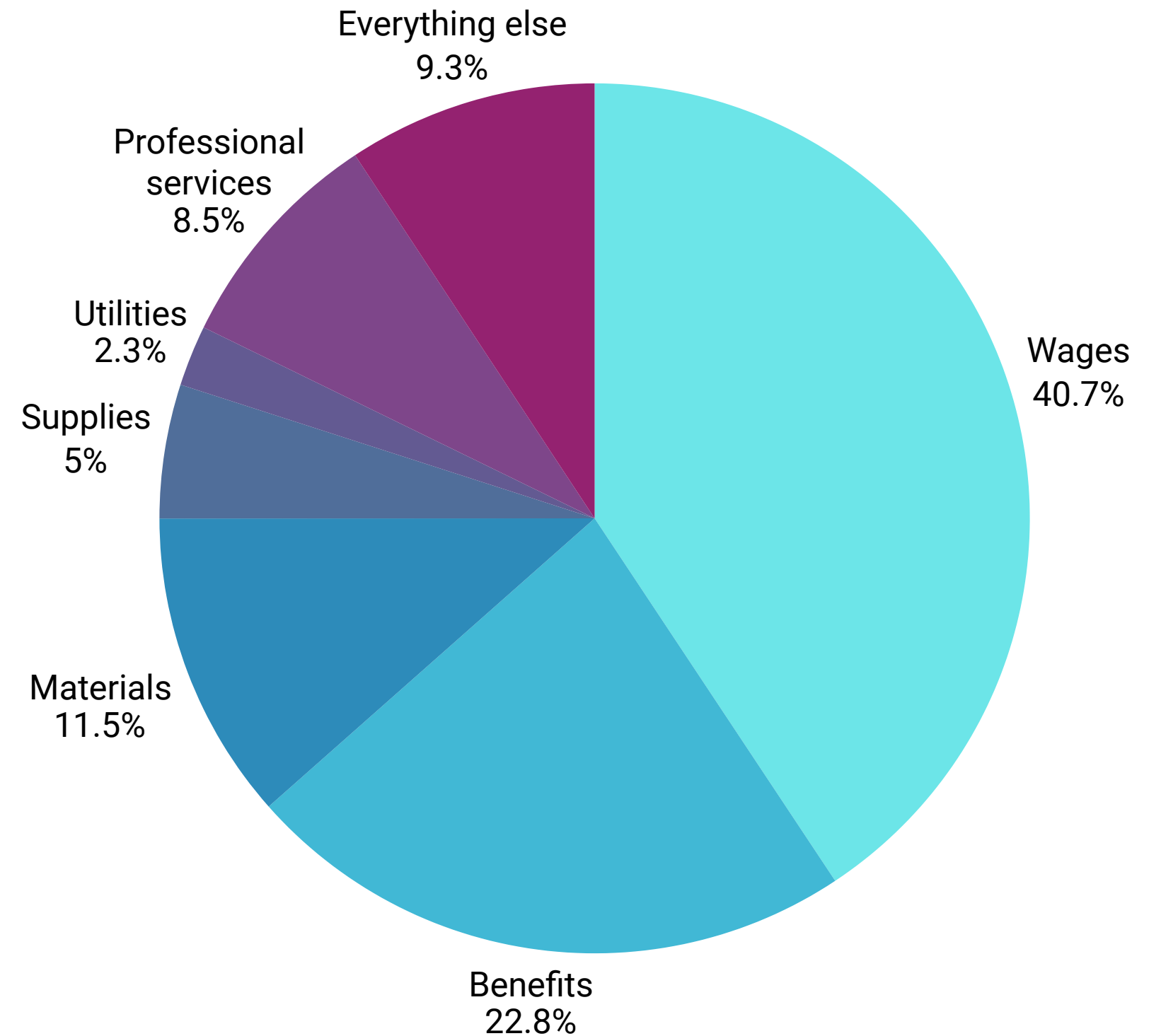

Total Operating Expenses \$1,457,832

Operating Revenue 2025

Property tax revenue- \$973,762
(levy @ \$0.25)

Sedro-Woolley payment - \$121,236

Capital payment: \$352,916

Timber revenue - \$90,931

Interest revenue- \$85,283

Everything else- \$34,482

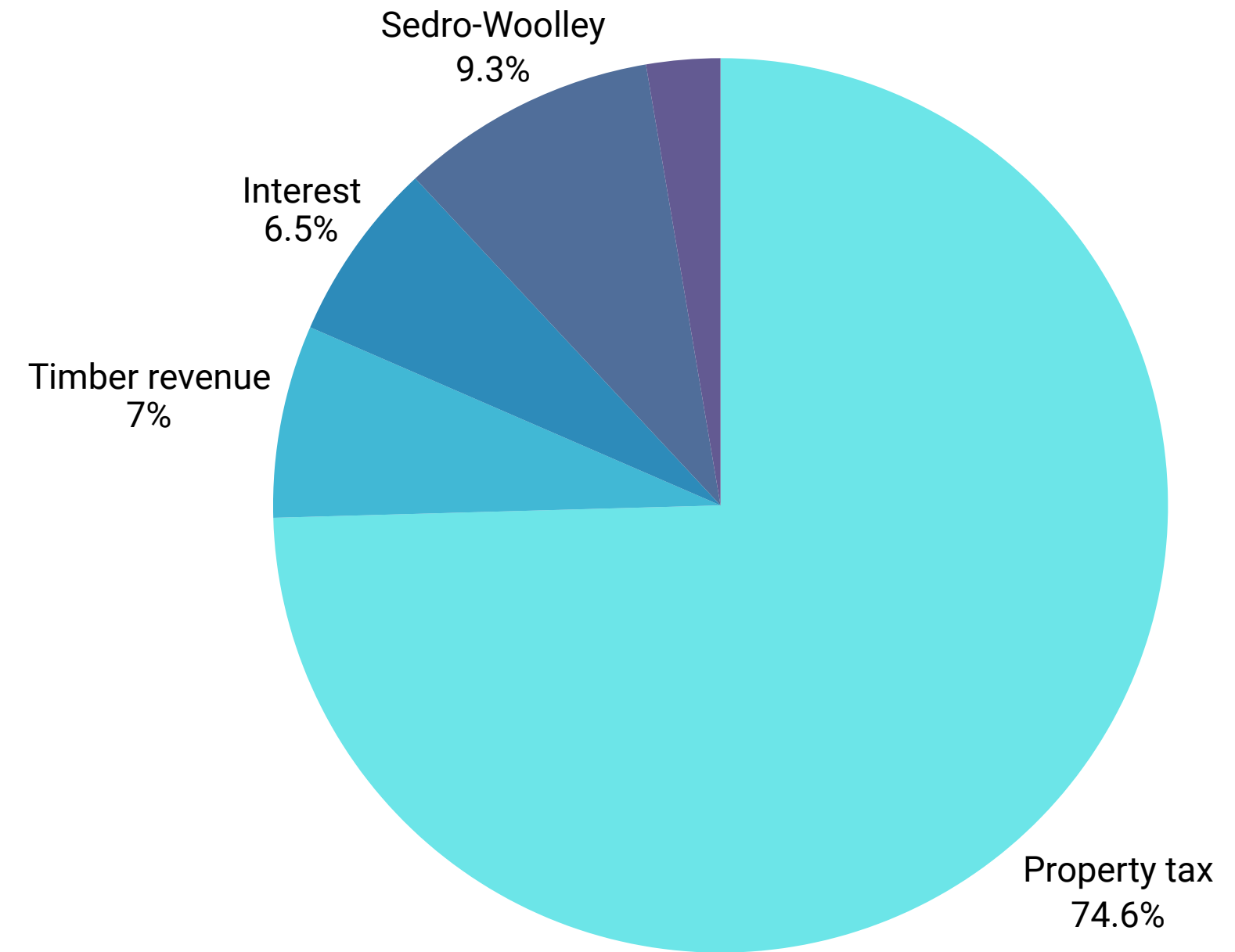

Total Operating Revenue \$1,305,054

2025 net \$ -152,778



PROGRAMS AND SERVICES

Adult Programs

- Board game nights
- Monthly crafternoon for adults
- Book clubs- romance and more
- Tech help at Sedro-Woolley Senior Center - partnership with Job Corps
- Monthly author visits and workshops
- Table top games weekly (D & D, etc.)

All materials provided

adult crafternoon

3rd Saturday | 1:30-2:30
OR
4th Friday | 4:30-5:30

Adults 18+

4 books 4 meetings

THE QUARTERLY BOOK CLUB
(formerly One Page at a Time)

January, April, July, and October
Second Wednesday at 6:00 PM

LUSTY LITERATES BOOKCLUB

Every 3rd Saturday @ 10:30-12:00

THIRST FOR LEARNING:

A monthly opportunity to learn something new.

First Thursdays
6:00 - 7:30 PM
Ages 18+

Adult Tabletop RPG Club
18+
6:00 - 9:00 PM

D&D 5e Every Wednesday!

Session 1 for our new 'Group 2' is on February 11th!

BOARD GAME NIGHTS

AGE 18+

6-9 PM

FIRST TUESDAY OF THE MONTH

Storytime

Pre-K Storytime: Ages 4-7 years
Tuesdays: 11:00 AM
 Join in the fun with stories, songs, activities and more that encourage the development of early literacy skills in young children.

Baby Storytime: Ages 0 - 12 months
Wednesdays: 10:30 AM
 Enjoy a social Storytime with baby. We'll talk, sing, read, and play to promote the earliest milestones of brain development

StoryTots Storytime: Ages 1 - 3 years
Fridays: 11:00 AM
 Try out our in-betweener group. We'll have just the right amount of playtime, songs, rhymes, and books to help boost your little one's early learning cognitive development.

TEEN KARAOKE NIGHT

Youth and teens

Weekly StoryTots and Preschool storytimes

Summer Reading

Outreach to local schools

Nerf Battles!

Monthly makerspaces

Weekly teen activities include:

- Crafts
- Dungeons & Dragons
- Teen Activities Council

TEEN DUNGEONS & DRAGONS CLUB

AGES 10 - 18
Tuesdays and Thursdays
4:00 - 5:45 PM

January 6th through August 27th

TEEN NERF BATTLE

Wednesday, January 28
 Nerf Battle 6:00 - 8:00
 110 West State Street

United General District 304 and Central Skagit Library present Teen Nerf Battle! Join us at Central Skagit Library for lots of fun Nerf games and snacks too!

Bring your own Nerf gun from home or borrow one from the library. (No round darts or mega darts, and please leave your ammo at home).

RISE | UNITED GENERAL DISTRICT 304 | Building Healthier Communities | Central Skagit Library District

Come play Capture the Flag • Humans vs. Zombies • Protect the President • And More!

TEEN CRAFT HANGOUT

Fridays
4:00 - 5:30 P.M.
Ages: 10-18

Pokémon Club

1st & 3rd Wednesday
 4:30 - 5:30 PM
 Ages 6 - 12

Come trade pokémon cards, do trivia, learn about pokémon and meet with friends!

Partnerships

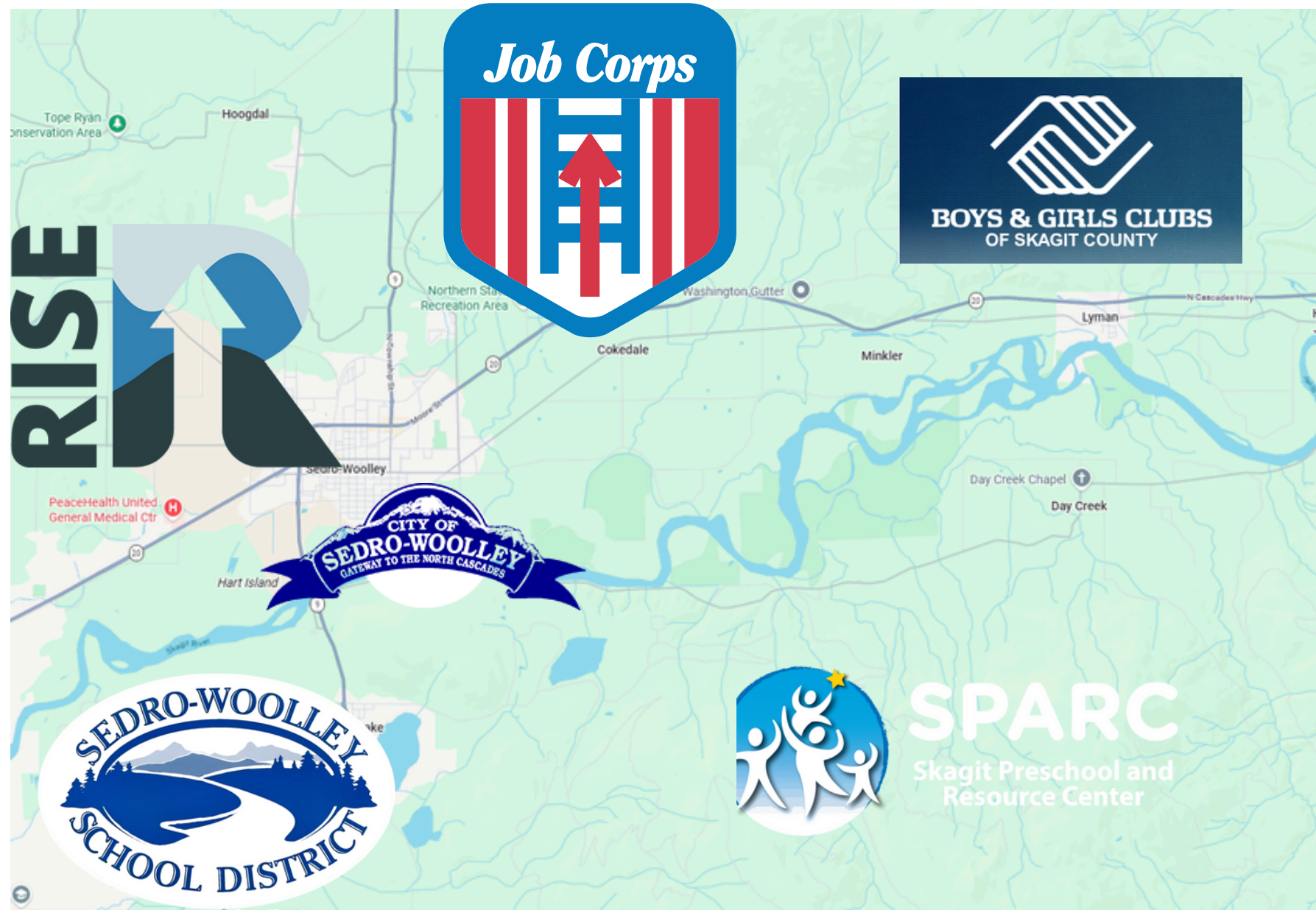

- Sedro-Woolley RISE
- Cascade Job Corps
- ATTIC (Washington Vocational Services)
- Sedro-Woolley School District
- Sedro-Woolley Recreation Center
- Sedro-Woolley Senior Center
- Boys & Girls Club
- Skagit County Parent2Parent
- And many, many more

Library usage 2023-2025

Library Visits

2024 - 2025 + 9.6%

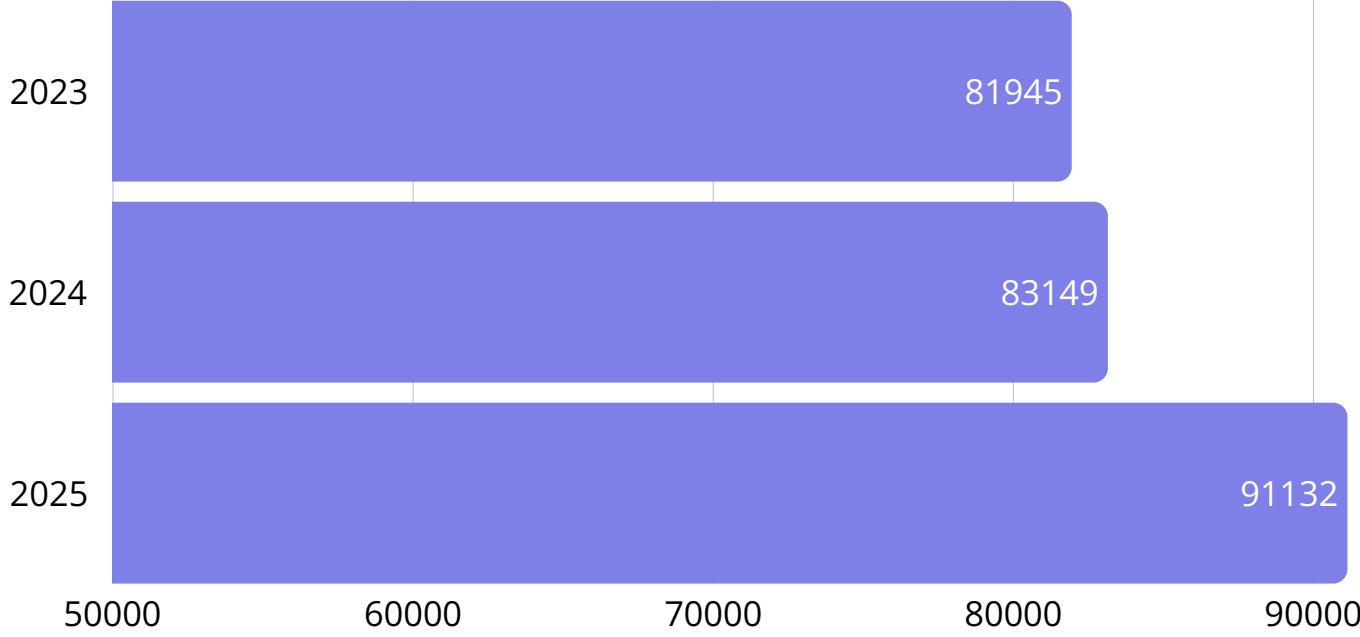

Total Library Circulation

2024 - 2025 + 2.2%

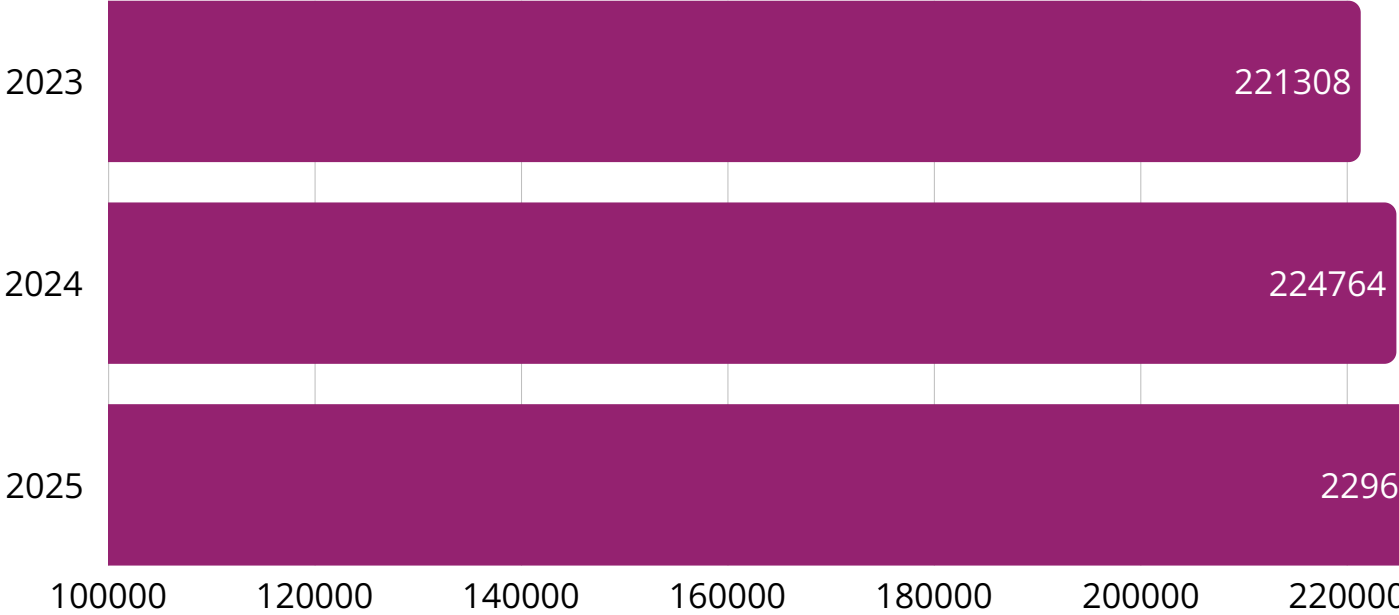

Meeting Room Use

2024 - 2025 + 13.3%

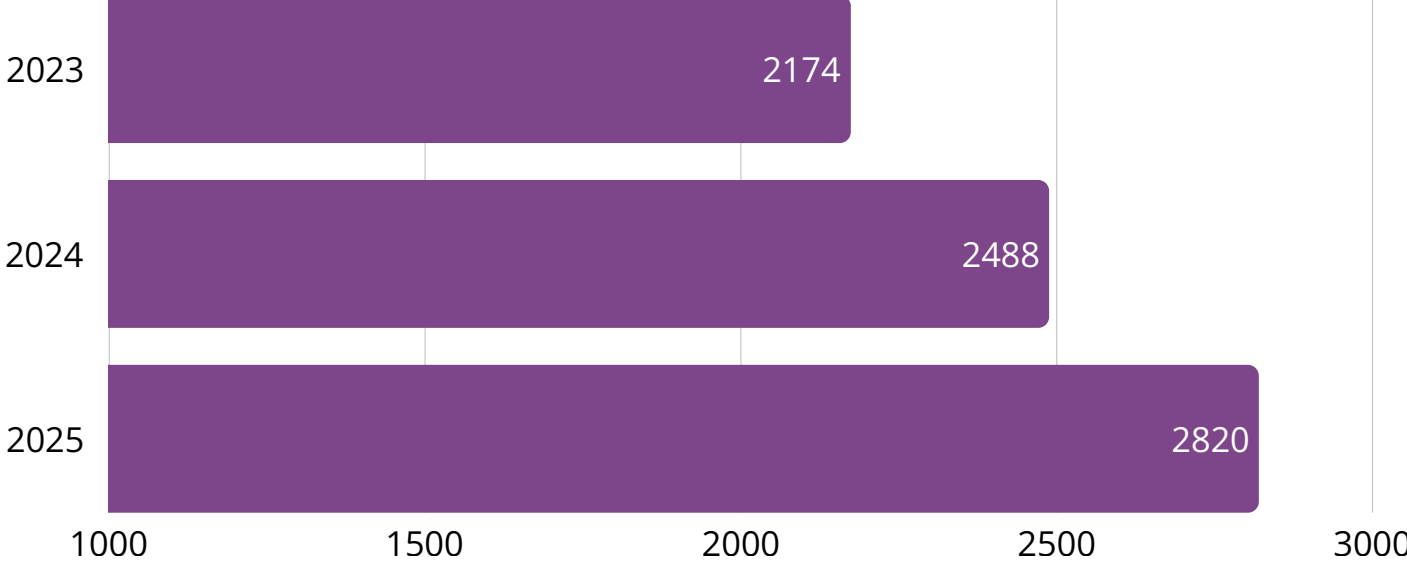

Program Attendance

2024 - 2025 + 10.4%

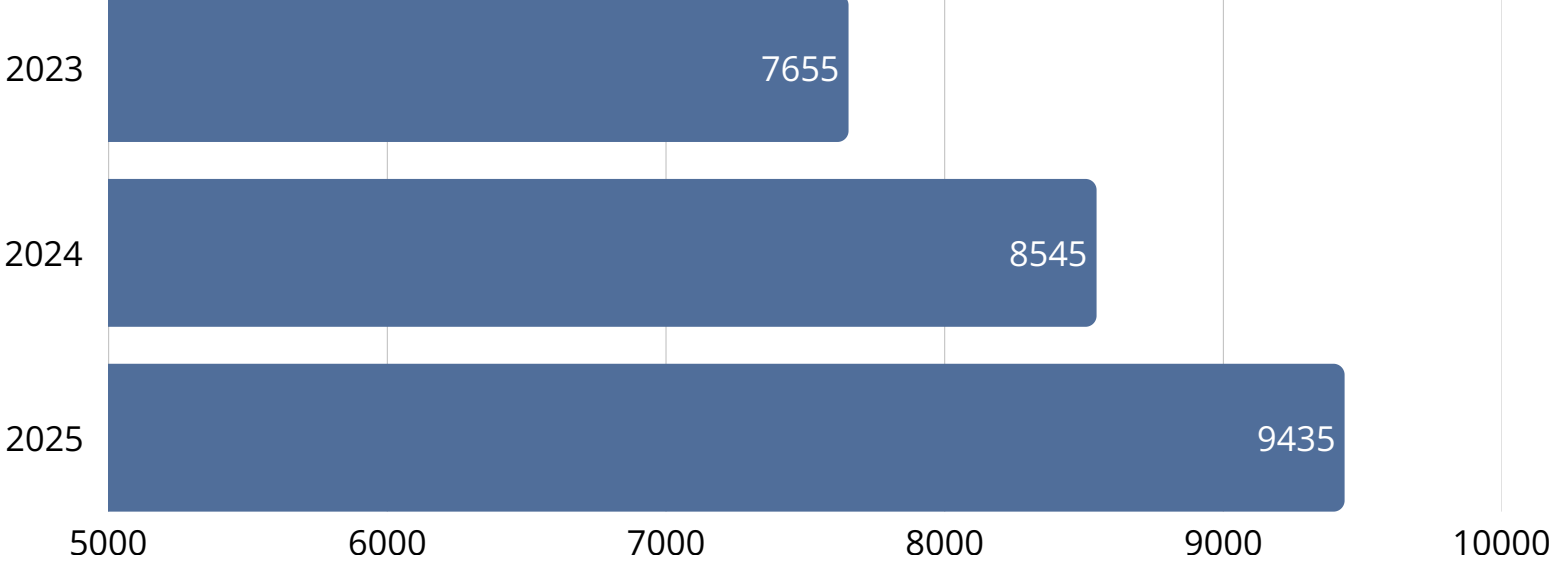



Looking Ahead

- Bilingual Outreach Manager beginning March 2026
- A new outreach vehicle
- Pop-up library locations throughout library district
- Continued partnership with regional Skagit libraries
- Strengthening existing community partnerships
- Dynamic collection analysis and response
- Finding new cost efficiencies

Levy Rate 2026

cents per \$1,000 property value

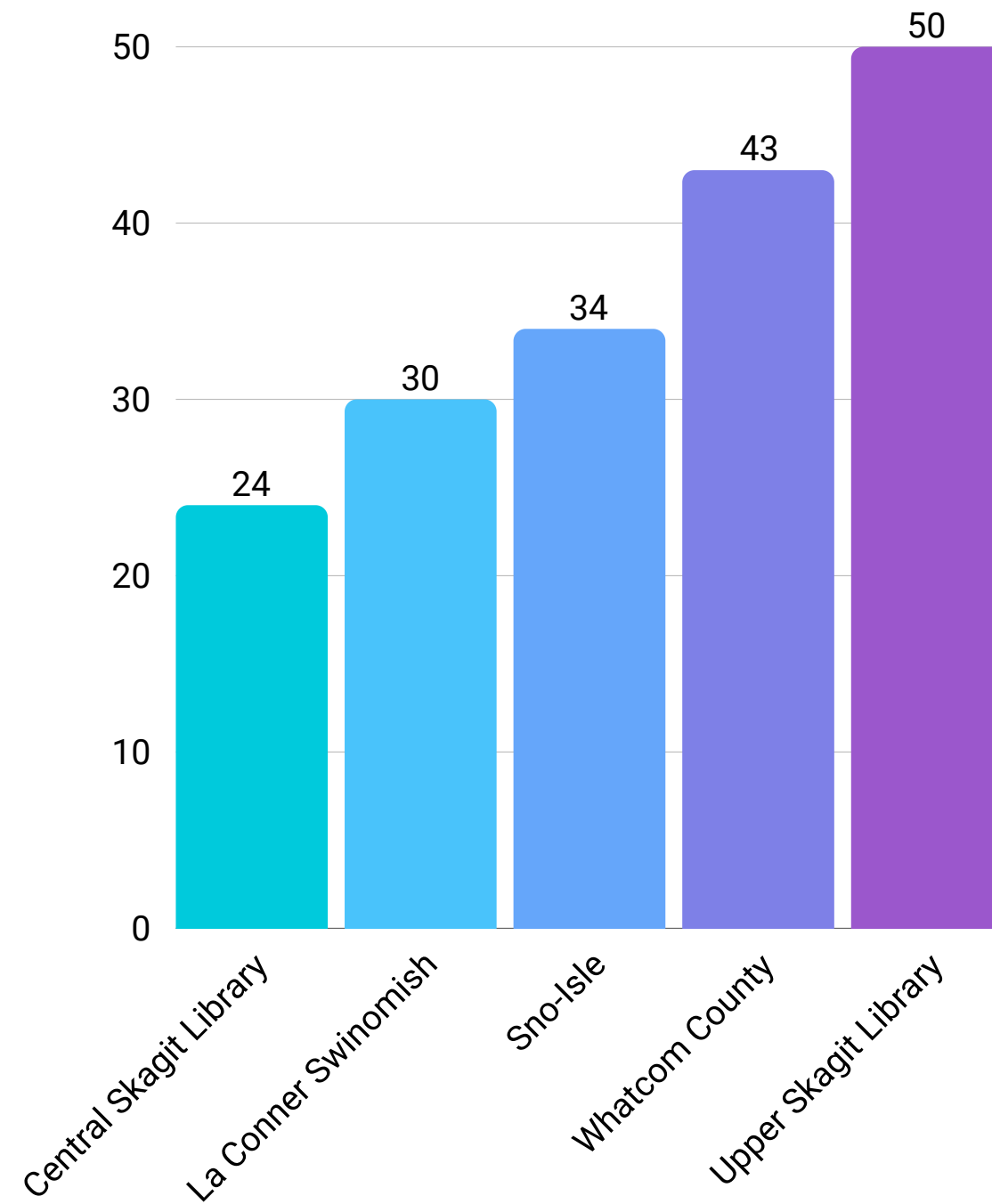

Per capita operating expenditures

Annual - 2024

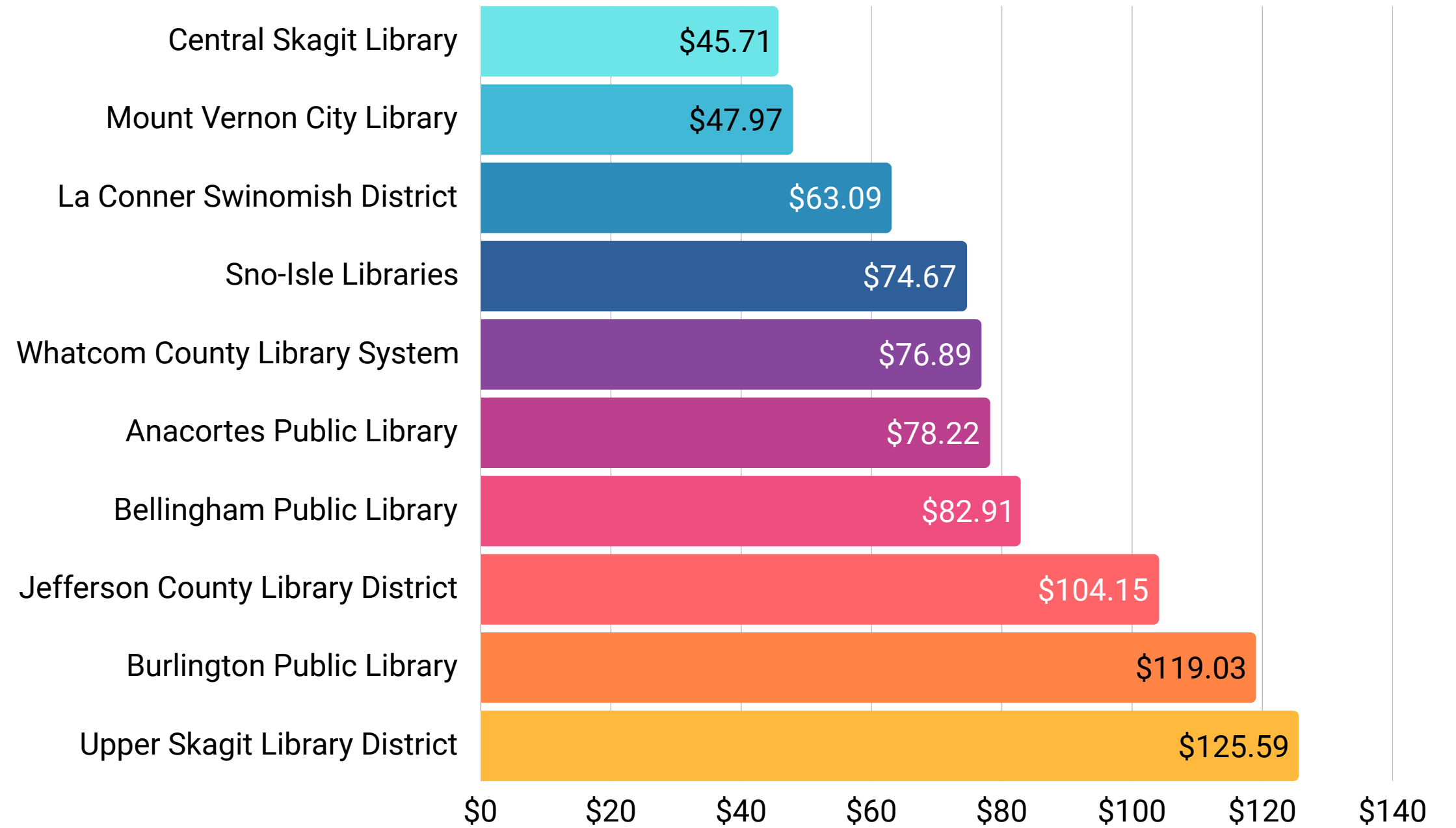

Questions?



Dan Owens, Library Director
dan@centralskagitlibrary.org

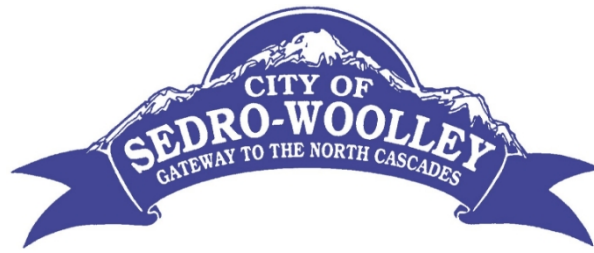

City Council Agenda Item

Agenda Item No.: m.1.

Date: February 11, 2026

From: Bill Bullock, Public Works Director

Subject: Site Host Agreement – Amperage Group - Electric Vehicle Chargers

RECOMMENDED ACTION:

Motion to authorize the Mayor, or designee, to approve the assignment (sale) documents of the EV charging equipment (ownership, maintenance, and operation) at the 900 Metcalf Street EV charging site between EV Charging Solutions (EVCS) and the Amperage Group, LLC subject to any revisions recommended by the City Attorney.

BACKGROUND/SUMMARY INFORMATION:

On June 26, 2024, the City signed a Letter of Intent to host electrical vehicle charging stations at 900 Metcalf Street with EV Charging Solutions (EVCS). Section 18 of that agreement state,

18. Successors and Assigns

The covenants, conditions and agreements contained herein shall bind and inure to the benefit of EVCS and Site Host and their respective successors and assigns. EVCS may assign this Agreement to a third party upon prior written consent of Site Host. Site Host may not assign this Agreement to any third party without prior written consent of EVCS.

EVCS has requested consent to assign this agreement to Amperage Group, LLC, per this clause in the agreement. This action will results the following:

- Amperage assumes all responsibility of the Grant Program.
- Amperage assumes all responsibility of EVCS in the Site Host Agreement.
- EVCS will continue to operate the stations and is still responsible for their performance.
- EVCS has to backstop Amperage's performance.

Staff has no exception to this request.

FISCAL IMPACT, IF APPROPRIATE:

None.

ATTACHMENTS:

1. 2024-137-CN Agmt_EVCS_Site Host Agreement Sedro Woolley 900 Metcalf Final.docx

2. 12_31_2025 - EVCS AmpCap 2025 update
3. Amperage_Capital_EVCS_Energy_Northwest_Assignment_Terms



SITE HOST AGREEMENT

This Site Host Agreement (hereafter the “**Agreement**”) is effective as of July 12, 2024 (hereafter the “**Effective Date**”) by and between EV Charging Solutions, Inc., a California corporation with its principle at 11800 Clark Street, Arcadia, California 91006 (hereafter “**EVCS**”), and City of Sedro Woolley with its principal place of business located at 325 Metcalf St, Sedro-Woolley, WA 98284 (hereafter “**Site Host**”). EVCS and Site Host may collectively be referred to herein as the “**Parties**” or individually as “**Party**.”

RECITALS

WHEREAS, EVCS has access to public and/or private funding to install and operate Level II Charging and/or Direct Current Fast Charging (“**DCFC**”) stations used for charging and/or recharging electric vehicles (hereafter the “**Equipment**”); and

WHEREAS, this funding is intended to improve the availability and reliability of electric vehicle charging systems; and

WHEREAS, Site Host wishes to allow the construction, operation, and/or maintenance of one or more items of Equipment on its real property (hereafter “**Property**” and/or “**Site**”) in the location more specifically identified herein and also wishes to allow public use of the Equipment; and

WHEREAS, the Parties wish to collaborate by utilizing their respective resources to promote the electric transportation sector; and

WHEREAS, the Parties wish to share the revenue realized from the sale of electricity stemming from the utilization of the Equipment on the Property as more fully described below; and

WHEREAS, the Parties desire that this Agreement shall remain in effect, subject to the terms and conditions set forth below, for ten (10) years after the commissioning date (i.e., date when the Equipment is placed in service on the Property);

NOW, THEREFORE, in consideration of the promises set forth herein, and for other good and valuable consideration, the receipt and adequacy of which is hereby acknowledged, EVCS and Site Host agree as follows:

1. Recitals

The Parties agree that the foregoing Recitals are true, correct, and accurate.

2. EVCS’ General Obligations for Equipment and Services

EVCS shall provide the following equipment and services at EVCS sole expense:

- a) Purchase of the Equipment (consisting of **4 DCFC Stations** and **1 Level II Stations**), the general specifications for which are detailed in **Exhibit A** together with all other mechanical, electrical, and physical components necessary for the installation, connection, and operation of the Equipment in accordance with this Agreement (the Parties agree that the Equipment delivered to the Property shall be the same or similar to the equipment detailed in **Exhibit A**);
- b) Preparation of the Property and installation of the Equipment at the location(s) approved, specified and identified by Site Host (the “**Project Site**”) and performed by qualified and licensed contractor(s) in accordance with local codes, permitting, and inspection requirements, as detailed in **Exhibit B**. For the purposes of initially creating a rebate application and reserving funding for the Project, EVCS and Site Host may mutually agree to leave Exhibit B blank upon initial execution. Once funding is reserved and further feasibility and recommendations are made by EVCS’ electrical contractor in accordance with Site Host’s written approval, the Parties shall further specify the approved location(s) and Site design by mutual written agreement on Exhibit B;
- c) Payment of all costs of its contractors associated with the delivery, site preparation, installation, and setup of the Equipment at the Project Site;
- d) In EVCS’ sole discretion, design, installation, wiring, connection and integration of the charging system, consumption/use meters, and related equipment into the public power grid in a manner sufficient to allow operation of the charging station(s) and the ongoing metering of power usage from each charging port;
- e) Ongoing maintenance/repairs of the Equipment for the term of the Agreement;
- f) All necessary communications, instructions, and network systems to facilitate public use of the Equipment to charge electric vehicles;
- g) Periodic reports to Site Host on the utilization of the Equipment; and

3. Site Host General Obligations

Site Host shall undertake the following, at Site Host's sole expense:

- a) Provide full, complete and unfettered access to EVCS for the placement, use, and operation of the Equipment at the Project Site for the full term of this Agreement;
- b) As permitted under Chapter 12.44 of the Sedro-Woolley Municipal Code, the Site Host may close the lot for special events. Any closure would be temporary, likely only for a day or two and the frequency of special events is anticipated to be only one or two times per year.
- c) Provides the necessary temporary construction access for EVCS and its contractors for preparation of the Project Site and for installation of the Equipment;
- d) Provides necessary ongoing utility easements and / or access for installation, usage, and maintenance of power lines, conduits, meters and Equipment;
- e) Allow full, complete and unfettered ongoing access to the Project Site and Equipment in order for EVCS to collect, use, and distribute data;
- f) Will not knowingly allow the Equipment to be, and will take all reasonable steps to prevent the Equipment from being opened, accessed, modified, or repaired by anyone other than EVCS or its licensed contractors;
- g) Will not sell, alienate, hypothecate, transfer, assign, encumber or otherwise pledge the Equipment;
- h) Use best efforts to prevent damage and vandalism of any type to the Equipment;
- i) Will not, and will not permit or allow any third party to, open, move, modify, reverse engineer, or disassemble the whole or any part of the Equipment or any part thereof in any manner;
- j) Will not, and will not permit or allow any third party to, uninstall the Equipment;

- k) Allow EVCS and its approved contractors full, complete and unfettered access to the Project Site for installation, maintenance, repair, replacement and approved de-installation of the Equipment;
- l) Cause the Project Site to be maintained in a clean, safe, and orderly condition, utilizing at least the same standard as to which other areas at the Property that are under the Site Host's control are maintained;
- m) Assign to EVCS all right, title and interest in and to all and any rebates that Site Host may receive relating to the Equipment, and/or this Agreement; including, but not limited to, (a) rebates or other payments based in whole or in part on the cost or size of equipment, (b) performance-based incentives paid as periodic payments, (c) tax credits, grants or benefits, and (d) any other attributes, commodities, revenue streams or payments, in each of (a) through (d) under any present or future law, standard or program and whether paid by a utility, private entity or any governmental, regulatory or administrative authority.
- n) Assign EVCS all right, title and interests in and to environmental credits (e.g., carbon credits) relating to the Equipment, and/or this Agreement; including, but limited to electric vehicle charging or renewable energy credits or certificates, carbon credits and any similar environmental or pollution allowances, credits or reporting rights.
- o) Assign EVCS all right, title and interest in and to the enrollment of the Equipment into a demand response program and any and all economic benefit arising from such an enrollment. If demand response program benefits credits the Site Host utility bill, the utility bill credit will be used to offset cost of electricity described in paragraph 4 and subchapter d (4.d.) and demand charges described in paragraph 4 and subchapter e (4.e.) and if the demand response credits are in excess of demand charges and cost of electricity, EVC .S can request Site Host for reimbursement of such excess. The Site Host agrees to issue such a reimbursement within thirty (30) days of request by EVCS.
- p) Promptly execute the Easement Agreement upon the request of EVCS or the applicable utility service provider. In the event that such Easement Agreement is not executed by Site Host as described above, and if such failure or refusal to execute such agreement blocks or precludes the completion of installation of the Equipment on the Project Site, Site Host agrees that, in addition to all other rights and remedies available to EVCS hereunder, Site Host shall reimburse EVCS for all costs incurred by EVCS in connection with the preparation of the Project Site and/or the incomplete installation of the Equipment.
- q) Shall fully cooperate and promptly communicate with EVCS during the entire time period required by EVCS to complete the preparation of the Project Site and the

installation of the Equipment. Site Host understands and acknowledges that EVCS will expend a significant amount of time, resources and effort to assess the Project Site, secure funding for the installation of the Equipment, and initiate engineering and design for the Equipment. Site Host further understands and acknowledges that the timeframe for completion of the Equipment installation is in part dependent on third parties, such as utility providers, rebate and permitting authorities and grant organizations, and thus the amount of time it takes to complete installation of the Equipment at the Project Site is often outside of EVCS' control. Thus, Site Host agrees that its cooperation as described above is of the essence of this Agreement.

- r) Provide EVCS with prompt notified of the sale or transfer of the Project Site, which notice shall include current contact information of the buyer or transferee.

4. Revenue Sharing

The Parties agree that:

- a) The Equipment installed by EVCS is intended to generate revenue through the patronage of customers utilizing the Equipment placed with the Site Host.
- b) EVCS shall, in its discretion, determine the price/rate at which electricity shall be sold to consumers utilizing the Equipment.
- c) EVCS will collect the proceeds generated from the sale of electricity from the Equipment placed with the Site Host and pay Site Host **\$0.05** (five cents) for each kWh of electricity sold to customers utilizing the DCFC Equipment and **\$0.03** (three cents) for each kWh of electricity sold to customers utilizing Level II Equipment, plus 100% of the cost of electricity utilized by the equipment; in the event the Site Host is responsible to pay for the cost of such electricity usage. Site Host may, in Site Host's discretion, offer certain customers free or discounted charging rates, provided,

however, that EVCS will offset any revenue share amounts owed to Site Host by an amount proportionate to the reduction in revenue caused by such discounts. In the event there is a balance owed from Site Host to EVCS as a result of such discounts, Site Host shall remit payment to settle said balance within ninety (90) days of receipt of a request for payment from EVCS.

- d) In the event Site Host incurs any utility provider assessed incremental demand charges strictly in connection with the operation of the installed Equipment, Site Host shall present these charges, including any support and back-up documentation that substantiates the charges to EVCS, and EVCS shall reimburse Site Host for these substantiated charges within ninety (90) days of receipt of a request for payment from EVCS.
- e) EVCS at its sole option will have the right to own the electricity service meter, providing that the meter is separate and exclusively used to service the Equipment, and/or utility service account servicing the Equipment.
- f) EVCS will install a separate electric meter as allowed by the utility provider at the Property through which electrical costs shall be tracked.
- g) EVCS will have forty-five (45) days after the end of each calendar quarter, to remit the appropriate revenue share payment to Site Host. The billing cycle will begin on the first day of the quarter and end on the last day of that same calendar quarter. EVCS shall provide Site Host with a quarterly accounting statement within forty-five (45) days following the end of the previous quarter indicating the total amount of revenue generated, including any offsets or reductions to revenue, and the resulting net revenue share amount owed to Site Host.

- h) See Exhibit C for Site Host ACH payment information. If such information is provided, EVCS shall make all required payments via ACH direct deposit, until further notice from Site Host.

5. Term of Agreement:

The term hereof shall begin upon the Effective Date. The date the Equipment becomes operational will hereafter be referred to as the "Commencement Date." The term hereof shall expire (unless renewed or extended) ten (10) years from the Commencement Date (hereafter the "Termination Date"), unless sooner terminated in accordance with the provisions hereof.

a) Automatic One (1) Year Renewal Clause

This agreement will automatically renew at the end of each Term for a further term of one (1) year unless either party gives the other written notice of termination at least thirty (30) days but no earlier than ninety (90) days prior to the end of the relevant term.

b) Early Termination Clause

This Agreement may be terminated upon 30 (thirty) days' written notice to either party without penalty or fee in the following instances:

In the case of EVCS, at any time and for any reason prior to the submission of the permit application for construction of the Equipment, at the Project Site, or thereafter at any time in the event that EVCS determines that the construction or continued operation of the Equipment is impracticable or uneconomical.

In the case of Site Host, in the event the Commencement Date has not occurred within eighteen (18) months from issuance of the approved utility plan, and required utility easement, if applicable, provided that Site Host's rights to terminate under this section shall terminate upon the Commencement Date.

In the case of the Site Host having another need for this site, it has the ability to terminate this agreement for convenience with 30 days' written notice. If the Site Host terminates this agreement under this provision, then the Site Host will reimburse EVCS for all the cost incurred in the site, plus a 25% overhead and profit mark-up. The reimbursement amount shall be reduced 10% each year, after the beginning of operations. EVCS shall remove equipment in not more than 180 days from the termination date.

6. Ownership of Equipment and Content

EVCS shall retain title to and ownership of the Equipment. All the information, content, services and software displayed on, transmitted through, stored within, or otherwise used in connection with the use and operation of the Equipment, including, but not limited to

data, text, photographs, images, illustrations, video, html, source and object code, software, internet account access, advertising, and the like (collectively, the “Content”) is owned exclusively by EVCS. Once this Agreement is terminated EVCS shall remove equipment at no cost to the Site Host.

7. Installation Activities

EVCS shall, at its sole cost and expense, be responsible for all installation activities (hereafter "Installation Activities") required to support the operation of the Equipment, and services therewith, including the hiring and coordination of all vendors and contractors; the installation of electrical equipment, utility lines, hardware, and software; site preparation, trenching, repaving, and landscaping.

8. Limitations on Use of Project Site

The Project Site and related parking spaces made available to the Project Site may be used for providing publicly-accessible electric vehicle charging. Site Host shall provide EVCS, its employees and contractors with reasonable access to the parking spaces and Equipment and shall otherwise provide to EVCS the same amenities and services Site Host provides to other users of Site Host’s parking facilities.

9. Utility Charges

EVCS shall be responsible for all electricity costs associated with both the operation of the Equipment and the charging of electric vehicles from the Equipment. Site Host shall cooperate with EVCS efforts regarding provision of electricity to the Equipment. Neither Site Host nor EVCS has any responsibility or liability for interruption, curtailment, failure, or defect in the supply of utilities furnished to the Equipment.

10. Allocation of Environmental Benefits

Site Host assigns to EVCS any renewable energy credits, allowances, or other indicators of environmental benefit attributable to the presence of the Equipment for the entirety of the time the originally installed Equipment is installed at the site but for a minimum of ten (10) years. If this Agreement extends under paragraph 5 and subchapter a (5.a.) or renews under paragraph 5 and subchapter b (5.b.), then paragraph 10 shall continue to remain in effect through the updated termination date.

11. Signage

EVCS shall have the right to place project-related signage to denote the location of the Equipment and the services available and may place other signage or advertising at the Property as agreed to by the Parties and to the extent permitted by the Sedro-Woolley Municipal Code or, as required by Washington Administrative Code.

12. Publicity

During the term of this Agreement, neither party will use the other party's name, logos, trademarks or service marks in any manner without the other party's prior written approval.

13. Indemnification

a) EVCS shall indemnify and hold harmless Site Host, and any tenant, guest, customer, patron, officer, volunteer, or employee of Site Host, from and against any and all liability and expense of any kind, including reasonable attorneys' fees, arising from injuries or damages to persons or property resulting in any way arising from performance of this agreement. It is a condition of this indemnification provision that EVCS shall receive prompt notice from Site Host of any claim against Site Host for which indemnification from EVCS is claimed.

- b) Site Host agrees to indemnify EVCS, its officers, board, employees, and agents, and hold all of same harmless from and against any and all liability and expense of any kind, including reasonable attorneys' fees, arising from injuries or damages to persons or property resulting in any way from any act or negligence or willful misconduct of Site Host, its contractors, agents or employees. It is a condition of this indemnification provision that Site Host shall receive prompt notice from EVCS of any claim against EVCS.

14. Breach and Opportunity to Cure

If either party breaches this Agreement and fails to cure such breach within thirty (30) days after receipt of written notice of that breach, then the non-breaching party may terminate this Agreement effective as of the end of such thirty (30) day period. Additionally, either party may terminate this Agreement immediately if the other party (i) ceases to do business in the ordinary course; or (ii) either voluntarily or involuntarily files a bankruptcy petition which is not vacated within thirty (30) days of filing. No such termination will be deemed a waiver of any claim for damages by the non-terminating party.

If the Site Host breaches or wrongfully terminates the Agreement prior to the Termination Date, Site Host will be required to reimburse EVCS for all costs incurred relating to the installation of the Equipment within thirty (30) days of receipt of an invoice from EVCS. The Site Host will also be required to reimburse EVCS for the total amount of any rebates EVCS would have received relating to the Equipment, and/or this Agreement had the Agreement not been breached or wrongfully terminated.

15. Limitation of Liability

NO WARRANTY, CONDITION OR REPRESENTATION, EXPRESSED, IMPLIED, ORAL OR STATUTORY, IS PROVIDED TO THE SITE HOST OR ANY THIRD PARTY, INCLUDING, WITHOUT LIMITATION, ANY WARRANTY, CONDITION OR REPRESENTATION: (A) OF MERCHANTABILITY, FITNESS FOR A PARTICULAR PURPOSE, SATISFACTORY QUALITY, OR ARISING FROM A COURSE OF DEALING, USAGE, OR TRADE PRACTICE; (B) THAT THE EQUIPMENT WILL BE FREE FROM INFRINGEMENT OR VIOLATION OF ANY RIGHTS, INCLUDING INTELLECTUAL PROPERTY RIGHTS OF THIRD PARTIES; OR (C) THAT THE OPERATION OF ANY SOFTWARE OR HARDWARE SUPPLIED WILL BE UNINTERRUPTED OR ERROR FREE. THIS DISCLAIMER AND EXCLUSION SHALL APPLY EVEN IF THE EXPRESS WARRANTY HEREIN FAILS OF ITS ESSENTIAL PURPOSE. THE SITE HOST'S SOLE AND EXCLUSIVE REMEDIES HEREUNDER AND THE ONLY LIABILITY OF SITE HOST IS EXPRESSLY LIMITED TO THE TERMS OF THE AGREEMENT. EVCS SHALL NOT BE LIABLE TO THE SITE HOST, OR ANY THIRD PARTY, FOR ANY OTHER SPECIAL, CONSEQUENTIAL, INCIDENTAL, EXEMPLARY OR

INDIRECT COSTS OR DAMAGES, INCLUDING WITHOUT LIMITATION, LITIGATION COSTS, LOSS OF DATA, LOSS OF PRODUCTION, AND/OR LOSS OF PROFIT ARISING FROM ANY CAUSE WHATSOEVER, REGARDLESS OF THE FORM OF THE ACTION, WHETHER IN CONTRACT, TORT (INCLUDING NEGLIGENCE), STRICT LIABILITY, OR OTHERWISE, EVEN IF ADVISED OF THE POSSIBILITY OF SUCH COSTS OR DAMAGES.

FOR PURPOSES OF THIS PROVISION, EVCS INCLUDES EVCS' DIRECTORS, OFFICERS, EMPLOYEES, AGENTS, REPRESENTATIVES, AFFILIATES, CONTRACTORS, SUBCONTRACTORS, AND SUPPLIERS. NOTWITHSTANDING ANYTHING HEREIN TO THE CONTRARY, ANY CLAIMS FOR DAMAGES BY EITHER PARTY ARISING UNDER OR IN CONNECTION WITH THIS AGREEMENT SHALL BE LIMITED TO ACTUAL RECOVERIES UNDER SUCH PARTY'S INSURANCE POLICIES.

THIS PROVISION IN NO WAY LIMITS OR MODIFIES THE INDEMNIFICATION REQUIREMENTS CONTAINED IN SECTION 13 HEREIN.

16. Disputes

This Agreement is governed by, and must be construed and enforced in accordance with, the laws of Washington, excluding principles of conflicts of laws. For every dispute regarding this Agreement: (i) each party shall pay its costs, expenses, and attorney fees (whether incurred at trial, on appeal, or otherwise) incurred in resolving or settling the dispute. No waiver of any provision or breach hereof is a waiver of any other provision or breach. All rights and remedies are cumulative and nonexclusive.

17. Notices

All notices and other communications provided hereunder must be in writing and will be deemed given: (i) on the date of hand-delivery; (ii) on the date when sent by facsimile (with confirmation of transmission); (iii) on the date when sent by email, with confirmation of receipt; (iv) the day after sending by a nationally recognized overnight delivery service (with confirmation of transmission); or (v) 3 days after sending by certified mail (return receipt requested).

For purposes of this Agreement, addresses for notification, unless changed from time to time in writing, shall be:

FOR EVCS:

EV Charging Solutions, Inc.
Attn: Thais Grossi,
Chief Operating Officer
11800 Clark Street
Arcadia, California 91006
thaisg@evcs.com
323.400.EVCS (3827)

Salesperson: Cyan Strategies, McKay

Rebate Program: ZEVIP 2023

SITE HOST:

SECONDARY/EMERGENCY CONTACT:

Company: City of Sedro-Woolley__

Company: City of Sedro-Woolley__

Attn: Bill Bullock, Public Works__

Attn: Nathan Salseina, Public Works

Add. 1: 325 Metcalf Street_____

Add. 1: 325 Metcalf Street_____

Add. 2: Sedro-Woolley, WA 98284_

Add. 2: Sedro-Woolley, WA 98284__

Email: bbullock@sedro-woolley.gov

Email: nsalseina@sedro-woolley.gov

Phone: 360-855-9931_____

Phone: 360-856-5167_____

18. Successors and Assigns

The covenants, conditions and agreements contained herein shall bind and inure to the benefit of EVCS and Site Host and their respective successors and assigns. EVCS may assign this Agreement to a third party upon prior written consent of Site Host. Site Host may not assign this Agreement to any third party without prior written consent of EVCS.

19. Entire Agreement

This Agreement contains all the agreements between the parties hereto and may not be modified in any manner other than by agreement in writing signed by both the parties hereto and their successors in interest.

IN WITNESS WHEREOF, this Agreement is executed by both parties, to become effective on the date last executed.

EVCS

SITE HOST

By: DocuSigned by:
Gustavo Occhiuzzo
708BF204CAG343C...

By: DocuSigned by:
Julia Johnson
EBB2DA0D1502400...

Printed Name: Gustavo Occhiuzzo

Printed Name: Julia Johnson

Title: CEO

Title: Mayor

Date: _____

Date: _____

EXHIBIT A - Electric Vehicle Charging Station Equipment Specifications

- 150 kW DC Fast Charger (4) – Noodoe 150P DCFC or equal
- 7.6 kW Level 2 EVSE (1) – Noodoe AC7LC and or equal

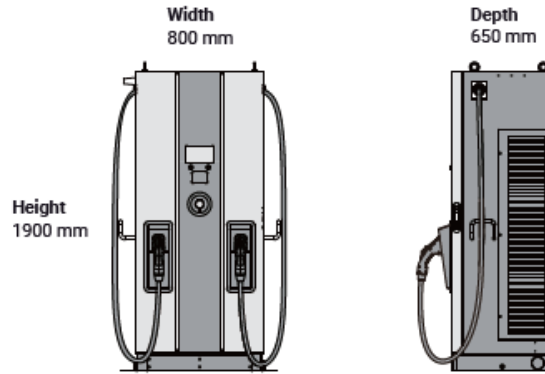

SPECIFICATIONS

Cloud service	Noodoe EV OS
Maximum output power	150 kW
Output power	CCS2: 200 A @150~500 Vdc or 157 A @950 Vdc CHAdeMO: 120 A @150~500 Vdc
Vehicle connector	CCS2, CHAdeMO
Charging cable length	4 m
Input power	3-phase, 5-wire, 380~415 Vac, 276 A maximum
Grounding system	TN, TT, IT
Efficiency	> 94%
Power factor	> 0.99
Display	7 inch LCD
Communication protocol	OCPP 1.6 JSON
Vehicle communication interface	ISO 15118
Network connectivity	Ethernet, Wi-Fi, 4G
RFID	RFID ISO/IEC 14443 A/B
Ingress protection(IP)	IP55
Impact protection	IK10
Electrical protection	Over voltage protection, over current protection, over power protection, over temperature protection, under voltage protection, surge protection device, insulation monitoring device, short circuit protection
Operating temperature	-30 °C to +50 °C
Dimensions	800 (W) x 1900 (H) x 650 (D) mm
Weight	450 kg
Certifications	CE, RED

Noodoe EV OS



Noodoe Corp.
15F, No.19-13,
Sanchong Road,
Nangang District,
Taipei City 11501,
Taiwan
+886 2 7722 0677
info@noodoe.com
noodoe.com

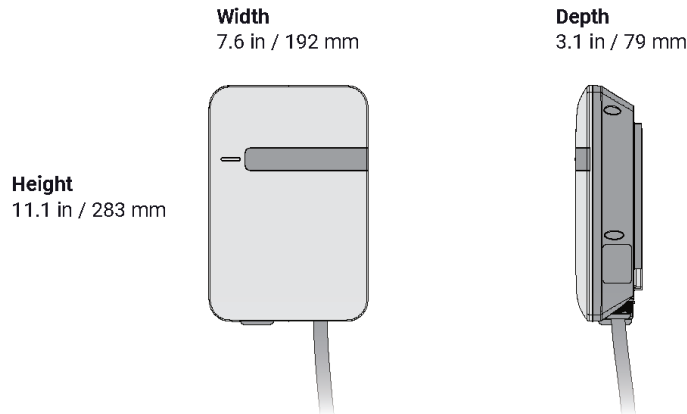

SPECIFICATIONS

Cloud service	Noodoe EV OS
Maximum output power	7.6 kW
Output power	32 A @208~240 Vac, 1-phase
Vehicle connector	SAE J1772
Charging cable length	25 feet / 7.6 m
Input power	1-phase, 3-wire, 208~240 Vac, 32 A maximum
Grounding system	TN, TT
Efficiency	> 99%
Power factor	> 0.99
Display	LED indicator, OLED, 20 characters, 2 lines
Communication protocol	OCPP 1.6 JSON
Network connectivity	Wi-Fi, 4G
RFID	RFID ISO/IEC 14443 A/B, ISO 15693
NEMA enclosures(NEMA)	NEMA 4
Impact protection	IK10
Electrical protection	Over voltage protection, under voltage protection, surge protection, ground fault protection, residual current device, short circuit protection, over current protection, over temperature protection
Operating temperature	-22 °F to +122 °F / -30 °C to +50 °C
Dimensions	7.6 (W) x 11.1 (H) x 3.1 (D) in 192 (W) x 283 (H) x 79 (D) mm
Weight	11 lbs / 5 kg
Certifications	UL, FCC, Energy Star

Noodoe EV OS



Noodoe Inc.
9896 Bissonnet,
Suite 440
Houston, TX 7703,
United States
+1 281-888-3429
info@noodoe.com
noodoe.com

EXHIBIT B – Project Site Info

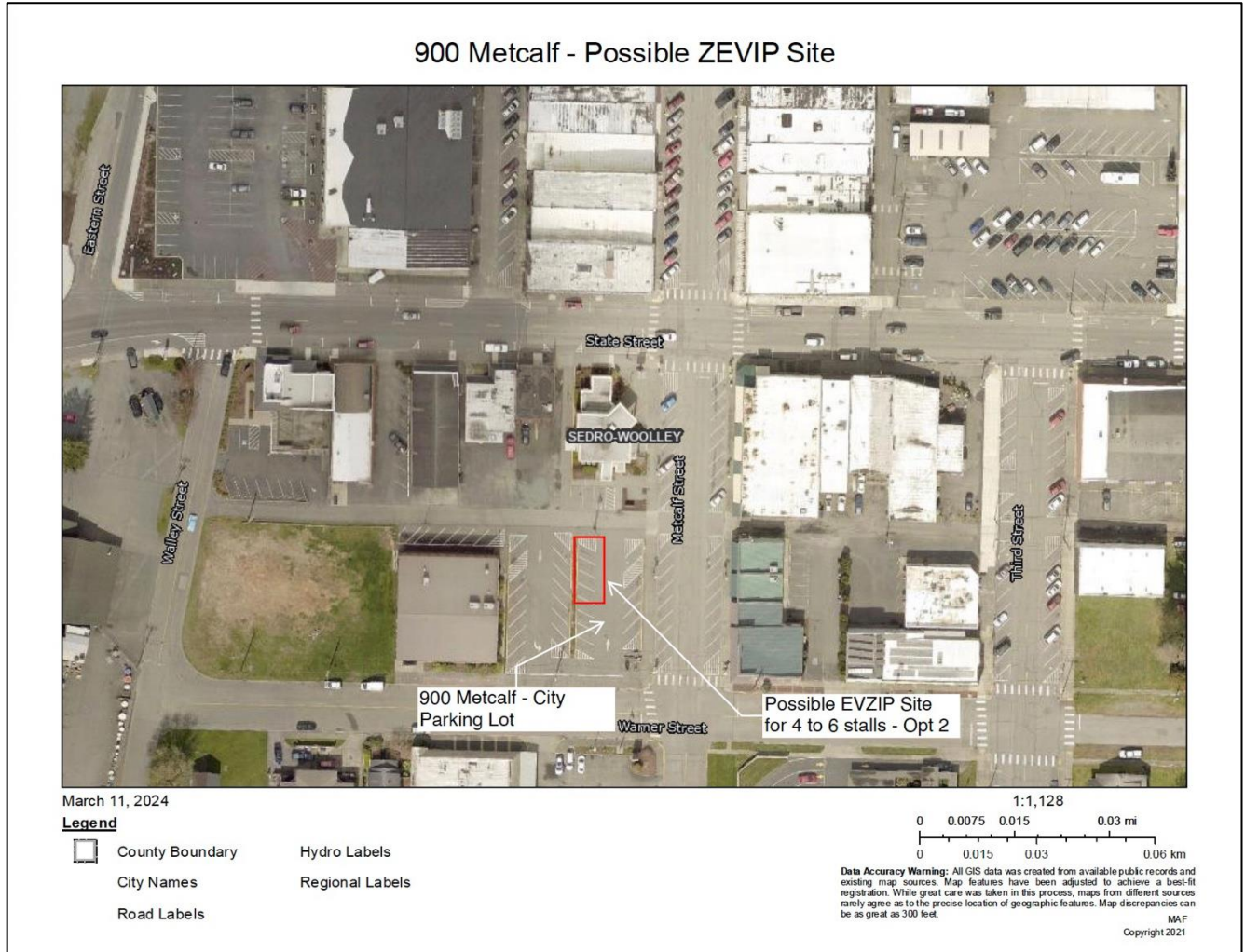

Utility/Electric Provider: Puget Sound Energy _____

Electric Provider Acct. #: _____

Total Estimated Parking Spaces: _____ / Estimated Number of ADA Spaces: _____

Other: _____

EV Charging Solutions | 11800 Clark St. Arcadia, CA 91006 | P 323.400-EVCS (3827) | www.evcs.com

EXHIBIT C – Site Host Banking Information (for ACH Payment Purposes)

Name on Account: Please contact Finance Director Kelly Kohnken for this information _____

Name of Bank: _____

Bank Account Number: _____

Bank Routing Number: _____

Agreement and Bill of Sale

Dated as of DATE, 2025 (the "Effective Date")

AMPERAGE GROUP, LLC, a Texas limited liability company (the "Buyer") with a place of business at 5900 Balcones Drive, Austin, Texas 78731, wishes to purchase, and **EV Charging Solutions, Inc.**, a California corporation located at 11800 Clark St., Arcada, CA 91006 (the "Seller") is willing to sell, the personal property described on Exhibit A attached hereto and incorporated herein by reference and made a part hereof (collectively, the "Assets") and to assign the grants described in Exhibit A-1 attached hereto and incorporated herein by reference and made a part hereof (collectively, the "Grant Awards"), subject to the terms of this Agreement and Bill of Sale ("Bill of Sale"). Seller and Buyer may be referred to herein, individually, as a "Party" or, collectively, as the "Parties" hereto.

1. The purchase price for the Assets listed in Exhibit A for a total of (redacted) US Dollars (the "Purchase Price"). Buyer shall pay the Purchase Price to Seller on the Effective Date by wire transfer in accordance with Seller's written wiring instructions. Transfer of the Assets shall be conditioned upon Seller's receipt of the Purchase Price. Buyer acknowledges that it has examined the Assets as fully as it desired. Each Party shall be responsible for its own costs incurred in connection with the transactions contemplated by this Bill of Sale. Buyer shall be responsible for all sales, use or other transfer taxes, if any, imposed by reason of the transfer of the Assets hereunder ("Taxes"). Taxes are not included in the Purchase Price. Buyer shall promptly reimburse Seller for any Taxes paid by Seller.

2. The Seller, for the Purchase Price and other good and valuable consideration, the receipt and sufficiency of which are hereby acknowledged, hereby conveys, grants, bargains, sells and transfers, to the Buyer, all of Seller's right, title and interest in and to the Assets and Grant Awards. The Assets will be delivered in situ.

3. BUYER ACKNOWLEDGES AND AGREES THAT THE ASSETS ARE BEING SOLD AND TRANSFERRED "AS IS, WHERE IS" AND, ACCORDINGLY, SELLER IS NOT MAKING ANY COVENANTS, GUARANTEES, REPRESENTATIONS OR WARRANTIES, WRITTEN OR ORAL, STATUTORY, EXPRESS OR IMPLIED, CONCERNING SUCH ASSETS, INCLUDING, IN PARTICULAR, AND WITHOUT LIMITATION, ANY COVENANTS, GUARANTEES, REPRESENTATIONS OR WARRANTIES WITH RESPECT TO (I) TITLE, (II) QUALITY OR SAFETY OF THE ASSETS, (III) MERCHANTABILITY, USAGE, SUITABILITY OR FITNESS FOR A PARTICULAR PURPOSE, (IV) WORKMANSHIP OF THE ASSETS OR THE ABSENCE OF ANY DEFECTS THEREIN, WHETHER LATENT OR PATENT, (V) COMPLIANCE WITH ENVIRONMENTAL REQUIREMENTS, (VI) THE CONDITION OF THE ASSETS, IN WHOLE OR IN PART, OR (VII) WHETHER THE BUYER POSSESSES SUFFICIENT REAL PROPERTY, PERSONAL PROPERTY OR OTHER RIGHTS, PERMITS OR LICENSES TO OWN, USE, OPERATE OR MAINTAIN THE ASSETS, ALL OF WHICH ARE HEREBY EXPRESSLY EXCLUDED AND DISCLAIMED. BUYER ACKNOWLEDGES AND AGREES THAT WARRANTIES PROVIDED BY ORIGINAL MANUFACTURERS, LICENSORS, OR PROVIDERS OF THE ASSETS, IF ANY, OR ANY ITEMS INCORPORATED THEREIN, ("THIRD PARTY WARRANTIES") ARE NOT TO BE CONSIDERED WARRANTIES OF SELLER, AND SELLER MAKES NO COVENANTS, REPRESENTATIONS, GUARANTEES, OR WARRANTIES AS TO THE EXISTENCE, APPLICABILITY OR ENFORCEABILITY OF ANY SUCH THIRD PARTY WARRANTIES.

SELLER FURTHER SPECIALLY DISCLAIMS ANY REPRESENTATION OR WARRANTY REGARDING THE ABSENCE OF HAZARDOUS SUBSTANCES (AS HEREINAFTER DEFINED) OR LIABILITY ARISING UNDER ENVIRONMENTAL LAWS

(AS HEREINAFTER DEFINED). WITHOUT LIMITING THE GENERALITY OF THE FOREGOING, SELLER EXPRESSLY DISCLAIMS ANY COVENANT, REPRESENTATION OR WARRANTY OF ANY KIND REGARDING THE CONDITION OF THE ASSETS OR THE SUITABILITY OF THE ASSETS FOR OPERATION FOR THE TRANSMISSION OR DISTRIBUTION OF ELECTRICITY. NO MATERIAL OR INFORMATION PROVIDED BY, OR COMMUNICATION MADE BY, SELLER, OR ANY OFFICER, EMPLOYEE, REPRESENTATIVE, CONSULTANT OR AGENT THEREOF, WILL CAUSE OR CREATE ANY COVENANT, GUARANTEE OR WARRANTY, STATUTORY, EXPRESS OR IMPLIED, RELATING TO THE ASSETS OR THIS BILL OF SALE. THE PROVISIONS HEREOF HAVE BEEN NEGOTIATED BY THE PARTIES HERETO AFTER DUE CONSIDERATION AND ARE INTENDED TO BE A COMPLETE EXCLUSION AND NEGATION OF ANY GUARANTEES, REPRESENTATIONS AND WARRANTIES, WHETHER STATUTORY, EXPRESS OR IMPLIED.

4. Buyer hereby waives and releases Seller, its affiliates and its and its affiliates' officers, directors, employees, agents, contractors and representatives from liability for any loss, injury, or damage, whether personal or property, arising from or associated with the possession, use, or disposal of the Assets by Seller, its affiliates or its or its affiliates' agents, representatives, employees, clients, customers, invitees, or any other third parties.

(a) Buyer hereby assumes liability for any claims arising from or relating to:

- (i) the design of any of the Assets individually or as a whole;
- (ii) resale of the Assets by Buyer or any other person or entity;
- (iii) use of the Assets by Buyer or any other person or entity;
- (iv) disposal of the Assets by Buyer or any other person or entity;
- (v) disposal of any waste contained in the Assets by Buyer or any other person or entity;
- (vi) disposal of any wastes which may result from the use of the Assets by Buyer or any other person or entity; or
- (vii) loss of, or damage to, the Assets.

(b) Neither Party shall not be liable to the other Party or to any other person or entity for any consequential, indirect, special, incidental, multiple, or punitive damages in connection with or related to this Bill of Sale or the Assets, including, without limitation, damage claims based on causes of action for breach of contract, tort (including negligence), or any other theory of recovery, whether or not (i) such damages were reasonably foreseeable or (ii) the Party was advised or aware that such damages might be incurred.

(c) Buyer and Seller (each, an "*Indemnifying Party*") agree to indemnify, defend (at the option of the applicable Indemnified Party and with counsel reasonably satisfactory to such Indemnified Party), and hold harmless the other Party and its respective officers, directors, shareholders, employees, agents, contractors, direct and indirect parent companies, affiliates and subsidiaries, and its or their respective successors and assigns (each, an "*Indemnified Party*" and, collectively, the "*Indemnified Parties*"), to the fullest extent permitted by applicable law, from and against any and all costs, losses, expenses, damages, claims, liens, fines, penalties, encumbrances, obligations, actions, and causes of action of any kind whatsoever, whether at law or in equity, whether known or unknown, suspected or unsuspected, including, without limitation, reasonable attorneys' fees and other professional fees and expenses, third-party claims for personal injury or property damage, diminution in property value, and remediation costs (collectively, "*Claims*"), in each case, resulting from: (i) any misrepresentation or breach of a representation or warranty made by such Indemnifying Party in this Agreement; (ii) any breach of a

covenant, agreement or obligation of such Indemnifying Party in this Agreement; (iii) with respect to any Claim against Seller as an Indemnifying Party under this Section 4(c), any Claim under any Underlying Site Host Agreement (as defined below) or Grant Award relating to any obligation of Seller pursuant to such Underlying Lease or Grant Award or an obligation thereunder to the extent such obligation arose prior to the date such Underlying Site Host Agreement or Grant Award was assigned to Buyer in accordance with this Agreement, and (iv) with respect to any Claim against Buyer as an Indemnifying Party under this Section 4(c), any Claim under any Underlying Site Host Agreement or Grant Award relating to any obligation of Buyer pursuant to such Underlying Site Host Agreement or Grant Award or an obligation thereunder to the extent such obligation arose on or after the date such Underlying Site Host Agreement or Grant Award was assigned to Buyer in accordance with this Agreement. Such indemnification obligations shall apply, on a proportionate and comparative-fault basis. Except for liability arising due to Seller's willful misconduct, fraud, misrepresentation, the liability of Seller under this Section 4(c) shall be limited, and shall not exceed, to the amount of the Purchase Price actually paid by Buyer and received by Seller for the Assets.

(e) For purposes of this Bill of Sale, (i) the term "Environmental Laws" shall mean any and all federal, state and/or local statutes, laws, regulations, ordinances, rules, judgments, orders, decrees or other governmental requirements or restrictions relating to the environment or to emissions, discharges or releases of pollutants, contaminants, petroleum or petroleum products, chemicals, toxic or hazardous substances or wastes into the environment, including, without limitation, ambient air, surface water, ground water or land, or otherwise relating to the manufacture, processing, distribution, use, treatment, storage, disposal, transport or handling of pollutants, contaminants, petroleum or petroleum products, chemicals, toxic or hazardous substances or wastes or the cleanup or other remediation thereof, and (ii) the term "Hazardous Materials" shall mean and include any oils, petroleum products and any other toxic or hazardous wastes, materials and substances which are defined, determined or identified as such in any applicable federal, state and/or local Environmental Laws, or in any judicial or administrative interpretation of Environmental Laws.

5. Each Party represents that the following statements are true, correct and complete as of the Effective Date:

(a) the Party is validly existing and in good standing under the laws of the state in which it is organized;

(b) the Party has all requisite power and authority to execute and deliver this Bill of Sale, undertake its obligations hereunder and consummate the transactions contemplated hereby and this Bill of Sale constitutes the valid and legally binding obligation of the Party enforceable in accordance with its terms, except as the enforceability thereof may be limited by applicable bankruptcy, insolvency, reorganization or other similar laws affecting creditors' rights generally and by general equitable principles (regardless of whether enforceability is sought in a proceeding in equity or law);

(c) neither the execution of this Bill of Sale by the Party, nor the consummation by the Party of the transactions contemplated hereby, will constitute a violation of, or be in conflict with, or constitute or create a default under: any applicable charter, certificate of incorporation, bylaws, operating agreement or similar organizational documents of the Party, each as amended to date; any agreement or commitment to which the Party is a party or by which the Party or any of its properties is bound or to which the Party or any of such properties is subject, except for any consents pursuant to the terms of any Grant Award or incentive that was received by Seller in respect of the Assets that may be needed for the consummation of the transactions under this Bill of Sale, which will be obtained by Seller pursuant to Section 9 of this Bill of Sale; or any statute or any judgment, decree, order, regulation or rule of any court or governmental authority; and

6. Seller warrants and represents that the following statements are true, correct and complete as of the Effective Date:

- (a) Seller does not have actual knowledge, nor after reasonable inquiry should have knowledge, of any pending, active, threatened, or anticipated claims, demands, actions, proceedings, investigations, liens, or other legal or administrative matters of any kind, whether at law or in equity, arising out of or relating to the Assets, including any claims for personal injury, property damage, environmental liability, contractual disputes, or regulatory enforcement. Seller further represents that it has not received any written notice alleging any such claim or circumstance that would reasonably be expected to give rise to any such claim in connection with the Assets.
- (b) Seller does not have actual knowledge, nor after reasonable inquiry should have knowledge, of any pending, active, threatened, or anticipated claims, demands, actions, proceedings, investigations, liens, or other legal or administrative matters of any kind, whether at law or in equity, arising out of or relating to the Grant Award, including any claims for personal injury, property damage, environmental liability, contractual disputes, or regulatory enforcement. Seller further represents that it has not received any written notice alleging any such claim or circumstance that would reasonably be expected to give rise to any such claim in connection with the Grant Award. Seller further represents and warrants that all required reporting and all other obligations under the Grant Award have been timely and fully satisfied and are in compliance, and that there are no outstanding or unresolved obligations thereunder.

7. Risk of loss or damage to the Assets shall pass to Buyer upon execution and delivery of this Bill of Sale by both Parties.

8. Buyer and Seller agree that the Assets are not being sold for the purpose of disposal, but are being sold with the intent that the Assets be used by Buyer.

9. Seller represents and warrants that (i) each of the Site Host Agreements underlying or associated with the Assets (each, an “*Underlying Site Host Agreement*”), which are identified on Exhibit A, shall be assigned or otherwise transferred to Buyer within thirty (30) days following the Effective Date, pursuant to an assignment and assumption agreement substantially in the form attached as Exhibit B, and (ii) Seller shall obtain the necessary third party consents under the applicable Grant Awards, which are identified on Exhibit A-1, within thirty (30) days following the Effective Date, pursuant to an assignment and assumption agreement substantially in the form attached as Exhibit C.

(a) If any Underlying Site Host Agreement is not capable of being assigned or transferred to Buyer within such thirty (30) day period or the Grant Award is not able to be assigned, then the Purchase Price shall be reduced by an amount equal to the portion of the Purchase Price reasonably allocable to the Asset subject to such unassigned Underlying Site Host Agreement, as set forth in Exhibit A.

(b) In addition, if Buyer has paid any portion of the Purchase Price attributable to an Asset for which the related Underlying Site Host Agreement is not assigned or transferred as required herein, Seller shall reimburse Buyer for such amount within five (5) days after Seller’s receipt of Buyer’s written notice specifying the amount paid and the applicable Asset, which amount shall be consistent with the allocations set forth in Exhibit A.

(c) If a portion of the Purchase Price is reduced or reimbursed pursuant to clause (a) or

(c) of this Section 9, Buyer will transfer ownership to the applicable Assets back to Seller within three (3) business days thereafter.

(d) Each of Buyer and Seller shall use commercially reasonable efforts to effectuate the assignment of the Grant Award in accordance with its terms and any requirements imposed by the granting authority. Notwithstanding the foregoing, if the requirements or conditions imposed by the granting authority in connection with such assignment would, in Buyer's reasonable determination, impose an undue burden on Buyer, Buyer may, in its sole discretion, elect not to take assignment of the Grant Award. In such event, Seller shall reimburse Buyer in accordance with Section 9(b), and Buyer shall have no further obligation to pursue or complete the assignment of the Grant Award.

(e) If the Grant Award cannot reasonably be assigned within the time frame set forth above despite the Parties' commercially reasonable efforts, Buyer and Seller shall mutually agree to extend such time frame for an additional period as reasonably necessary to facilitate the assignment. If, after thirty (30) days following the expiration of the original time frame (as such time frame may be extended by mutual agreement), the Grant Award has not been assigned, Buyer may, in its sole discretion, elect not to take assignment of the Grant Award, in which event Seller shall reimburse Buyer in accordance with Section 9(b), and Buyer shall have no further obligation with respect to such assignment.

(d) The remedies set forth in this Section are without prejudice to any other rights or remedies available to Buyer under this Agreement or applicable law.

10. To the extent that any provision of this Bill of Sale shall be held to be invalid, illegal or unenforceable, it shall be modified so as to give as much effect to the original intent of such provision as is consistent with applicable law and without affecting the validity, legality or enforceability of the remaining provisions of this Bill of Sale. Each Party represents to the other Party that the signatory identified beneath its name below has full authority to execute this Bill of Sale on its behalf.

11. This Bill of Sale and all of the provisions hereof shall be binding upon and shall inure to the benefit of the Parties and their respective successors and assigns. Paragraphs 3, 4, 6, and 8 shall survive execution, delivery and completion of this Bill of Sale.

12. This Bill of Sale shall be governed by and construed in accordance with the laws of the State of New York (regardless of the laws that might otherwise govern under such state's applicable principles of conflicts of laws). Venue in any action with respect to this Bill of Sale shall be in the State of New York; the Parties agree to submit to the personal jurisdiction of courts in the State of New York with respect to any such actions.

13. This Bill of Sale may be executed in several counterparts, each of which shall be deemed an original when signed, and such counterparts shall constitute one and the same instrument. The exchange of counterparts by facsimile transmission (including telecopier and scanned "PDF" transmitted by email) shall constitute effective execution and delivery of this Bill of Sale by the Parties. Signatures of the Parties transmitted by facsimile (including telecopier and scanned "PDF" transmitted by email) shall be deemed to be their original signatures for all purposes.

IN WITNESS WHEREOF, the Parties have each caused this Bill of Sale to be executed in their names and behalf by their respective duly authorized representatives as of the Effective Date.

EV Charging Solutions, Inc. as Seller

By: _____
Name:
Title:

Amperage Group, LLC, as Buyer

By: _____
Name: Shannon Johnson
Title: Co-Founder

EXHIBIT A

DESCRIPTION OF ASSETS

1. EVCS Charging Stations are located at the following addresses:

Model Number	Station Name	Org Name	Address 1	City	State	Zip/Postal Code
4 Zerova 150kW + 1L2	Kitsap Bank - 8190 Kingston	Kitsap Bank	8190 NE State Highway 104	Kingston	WA	98346
1 Tritium 175 + 2 350kW ABB	Riverside Lanes - Mt Vernon	DYM Storkson Family Limited Partnership	225 Riverside Ln	Mount Vernon	WA	98273
3 Samsung 180kW + 1 200kW XCharge + 1L2	Sedro-Woolley Metcalf St	City of Sedro-Woolley	900 Metcalf St	Sedro-Woolley	WA	98284
3 Samsung 180kW + 1 200kW XCharge + 1L2	Tolt Towne Center - Carnation Market	LSR Properties Inc.	31722 West Eugene Street	Carnation	WA	98014
4 Samsung 100kW	Del Rio Country Club	Del Rio Gold & Country Club	801 Stewart Rd	Modesto	CA	95356

Asset Serial #	Hardware Type	Model #	Station Name	Lat	Long
N2249A001A1	Zerova 150kW	DSWU152J0UD5N0	Kitsap Bank - 8190 Kingston	47.8101569	- 122.5408873
C2308A003A1	Zerova 150kW	DSWU152J0UD5N0	Kitsap Bank - 8190 Kingston	47.8101569	- 122.5408873
C2308A002A1	Zerova 150kW	DSWU152J0UD5N0	Kitsap Bank - 8190 Kingston	47.8101569	- 122.5408873
C2308A001A1	Zerova 150kW	DSWU152J0UD5N0	Kitsap Bank - 8190 Kingston	47.8101569	- 122.5408873
6ND1-6-2249-00489	Lite-ON 7kW	EX-1762-6ND1	Kitsap Bank - 8190 Kingston	47.8101569	- 122.5408873
322100069	Tritium 175kW	TRI125-99-X1	Riverside Lanes - Mt Vernon	48.4393349	- 122.3365756
T175-IT1-1523-070	ABB 350kW Dispenser 1 of 2	MD_HVC_CAR	Riverside Lanes - Mt Vernon	48.4393349	- 122.3365756

T175-IT1-4322-181	ABB 350kW Dispenser 2 of 2	MD_HVC_CAR	Riverside Lanes - Mt Vernon	48.4393349	- 122.3365756
2512F1005	Samsung 180kW	JC-9932-180-CT	Sedro-Woolley Metcalf St	48.5031128	-122.238931
2514F1002	Samsung 180kW	JC-9932-180-CT	Sedro-Woolley Metcalf St	48.5031128	-122.238931
2514F1003	Samsung 180kW	JC-9932-180-CT	Sedro-Woolley Metcalf St	48.5031128	-122.238931
C6AM200JCALJUQMYAQ	200kW XCharge	C6EU	Sedro-Woolley Metcalf St	48.5031128	-122.238931
W1-1962-7ND1-6-2311- 00036	LiteON 9kW	W1-1962-7ND1	Sedro-Woolley Metcalf St	48.5031128	-122.238931
2512F1009	Samsung 180kW	JC-9932-180-CT	Tolt Towne Center - Carnation Market	47.6470781	- 121.9161931
2512F1010	Samsung 180kW	JC-9932-180-CT	Tolt Towne Center - Carnation Market	47.6470781	- 121.9161931
2512F1016	Samsung 180kW	JC-9932-180-CT	Tolt Towne Center - Carnation Market	47.6470781	- 121.9161931
C6AM200JCMSUVJGCCR	200kW XCharge	C6EU	Tolt Towne Center - Carnation Market	47.6470781	- 121.9161931
W1-1962-7ND1-6-2311- 00048	LiteON 9kW	W1-1962-7ND1	Tolt Towne Center - Carnation Market	47.6470781	- 121.9161931
2411F1004	Samsung 100kW	JC-9932-100CT	Del Rio Country Club	37.7440048	-121.004615
2411F1005	Samsung 100kW	JC-9932-100CT	Del Rio Country Club	37.7440048	-121.004615
2411F1008	Samsung 100kW	JC-9932-100CT	Del Rio Country Club	37.7440048	-121.004615
2411F1009	Samsung 100kW	JC-9932-100CT	Del Rio Country Club	37.7440048	-121.004615

The Underlying Site Host agreements associated with the Assets include the following:

The Purchase Price is allocated to the Assets as follows:

Station Name	Purchase Price
--------------	----------------

Kitsap Bank - 8190 Kingston	
Riverside Lanes - Mt Vernon	
Sedro-Woolley Metcalf St	
Tolt Towne Center - Carnation Market	
Del Rio Country Club	

EXHIBIT A-1

Grant Awards to be Assigned

	Leased Space s	Non - DCFC Space s	Commencemen t Date	SHA Years	Funding Partner	Agreemen t
Kitsap Bank - 8190 Kingston	4		7/16/2025	10	Forth - ZEVIP via WSDOT	UCB-1019
Riverside Lanes - Mt Vernon	4		6/1/2025	10	Forth - ZEVIP via WSDOT	UCB-1024
Sedro-Woolley Metcalf St	9	1 Level 2	12/11/2025	10	Energy Northwest - ZEVIP via WSDOT	GCB 3974
Tolt Towne Center - Carnation Market	9	1 level 2	12/15/2025	10	Forth - ZEVIP via WSDOT	UTC-1008
Del Rio Country Club	8		4/1/2025	10	San Joaquin Valley APCD	G-193120

EXHIBIT B

FORM OF ASSIGNMENT AND ASSUMPTION AGREEMENT

ASSIGNMENT AND ASSUMPTION AGREEMENT This ASSIGNMENT AND ASSUMPTION AGREEMENT (this “Agreement”), dated as of December 31st, 2025 (the “Effective Date”), is entered into by and between AMPERAGE GROUP, LLC, a Texas limited liability company (“Buyer”) and EVCS, LLC (“Seller”, and together with Buyer, the “Parties”), pursuant to Section 6.01(b) of that certain Agreement and Bill of Sale, dated as of December 31st, 2025 (the “Purchase Agreement”), by and between Buyer and Seller. Capitalized terms used herein and not otherwise defined herein shall have the respective meaning ascribed to them in the Purchase Agreement.

WITNESSETH:

WHEREAS, pursuant to the Purchase Agreement, Seller has agreed to sell and assign to Buyer, and Buyer has agreed to purchase and assume from Seller, all of Seller’s right, title and interest in and to the Underlying Site Host Agreements.

NOW, THEREFORE, in consideration of the mutual premises and covenants set forth herein and in the Purchase Agreement and for other good and valuable consideration, the receipt and sufficiency of which are hereby acknowledged, the Parties agree to the following:

1. Assignment and Assumption of Underlying Site Host Agreements. Seller hereby assigns and transfers the Underlying Site Host Agreements to Buyer, and Buyer hereby assumes and accepts such assignment and agrees to perform all of the terms, covenants and conditions in the Underlying Site Host Agreements therein that would, except for this assignment, be required to be performed on the part of Seller thereunder from and after the Effective Date.
2. Subject to Purchase Agreement. This Agreement is executed and delivered pursuant to the Purchase Agreement and is subject to the terms and conditions of the Purchase Agreement..
3. Entire Agreement. This Agreement and the Purchase Agreement embody the Parties’ entire agreement and there have been and are no agreements, representations or warranties, or written between the Parties other than those set forth or provided for in this Agreement or the Purchase Agreement.
4. Headings. The headings used in this Agreement are for purposes of convenience only and shall not be used in construing the provisions hereof.
5. Successors and Assigns. This Agreement shall bind and benefit the respective successors and permitted assigns of Buyer and Seller.
6. Governing Law. This Agreement shall be governed by, construed and enforced in accordance with the laws of the State of New York without giving effect to the choice of law principles thereof.
7. Modification. This Agreement may not be modified or amended except by the written agreement of Buyer and Seller.

8. Counterparts. This Agreement may be executed in one or more counterparts, each of which shall be deemed to be an original, but all of which shall be one and the same document. A signed copy of this Agreement delivered by facsimile, e- mail or other means of electronic transmission shall be deemed to have the same legal effect as delivery of an original signed copy of this Agreement. Electronic signatures using a nationally recognized service, such as DocuSign, is permitted.

IN WITNESS WHEREOF, the parties have caused this Agreement to be executed as of the date first above written.

**SELLER:
EV CHARGING SOLUTIONS, INC.**

By: _____
Its:

**PURCHASER:
AMPERAGE GROUP, LLC**

By: _____
Its:

EXHIBIT C

GRANT AWARD ASSIGNMENT AGREEMENT

GRANT AWARD ASSIGNMENT AGREEMENT. This GRANT AWARD ASSIGNMENT AGREEMENT (this “Grant Agreement”), dated as of December 31st, 2025 (the “Effective Date”), is entered into by and between AMPERAGE GROUP, LLC, a Texas limited liability company (“Buyer”) and EVCS, LLC (“Seller”, and together with Buyer, the “Parties”), pursuant to Section 6.01(b) of that certain Agreement and Bill of Sale, dated as of December 31st, 2025 (the “Purchase Agreement”), by and between Buyer and Seller. Capitalized terms used herein and not otherwise defined herein shall have the respective meaning ascribed to them in the Purchase Agreement.

WITNESSETH:

WHEREAS, pursuant to the Purchase Agreement, Seller has agreed to sell and assign to Buyer, and Buyer has agreed to purchase and assume from Seller, all of Seller’s right, title and interest in and to the Grant Award.

NOW, THEREFORE, in consideration of the mutual premises and covenants set forth herein and in the Purchase Agreement and for other good and valuable consideration, the receipt and sufficiency of which are hereby acknowledged, the Parties agree to the following:

1. Assignment and Assumption of the Grant Awards. Seller hereby assigns and transfers the Grant Award to Buyer, and Buyer hereby assumes and accepts such assignment and subject to this Grant Agreement, agrees to perform all of the terms, covenants and conditions in the Grant Award therein that would, except for this assignment, be required to be performed on the part of Seller thereunder from and after the Effective Date.
2. O&M Obligation Assignment. Pursuant to **ZEVIP Grant Agreement No. GCB 3974, UCB-1019, UCB-1024, UTC-1008**, the Project is subject to a minimum **five-year Performance Period** during which the charging infrastructure must be operated, maintained, and made publicly accessible in accordance with program requirements.

Upon completion of the purchase of the Site, **Amperage shall assume responsibility for all Performance Period obligations related to ownership, operation, and maintenance of the Site**, including but not limited to:

- Operation and maintenance of the electric vehicle supply equipment in compliance with the stated agreements ;
- Maintaining public accessibility, network functionality with 24/7 customer support, and required 97% uptime standards throughout the Performance Period;
- Performing necessary repairs, replacements, and annual preventative maintenance with qualified personnel to ensure continued compliance; and
- Take assignment of the existing Site Host Agreements expiring in 2035; and

- Cooperating with EVCS, WSDOT, Forth, and Energy Northwest to support ongoing compliance with the ZEVIP Agreement by way of audit, or documentation request

The total five-year value of the network and maintenance obligations was estimated at \$683,000 as a match-cost share to be provided by EVCS, which will now be provided by Amperage Capital and their operating partners. For clarity this includes revenue share as well as network + maintenance fees.

3. Reporting and Grant Administration. Notwithstanding the transfer of Site ownership, **EVCS shall retain responsibility for all quarterly reporting, data submission, grant administration, and 3. communications required under ZEVIP Grant Agreements**, as part of EVCS's ongoing contractual and operational relationship with Energy Northwest and Forth, the Prime Contractors under the ZEVIP Agreement. EVCS intends to fully support Amperage Capital fulfill the entirety of the ZEVIP Agreement and continued operation.

Amperage agrees to provide EVCS with timely access to operational data, usage metrics, maintenance records, uptime information, and any other Site-related documentation reasonably necessary for EVCS to fulfill its reporting and compliance obligations under The Agreement.

4. Transition and Ongoing Cooperation. The Parties agree to cooperate in good faith to facilitate an orderly transition of Site ownership and ongoing operations, including the transfer of technical documentation, site records, and reasonable coordination necessary to maintain uninterrupted compliance with the ZEVIP Agreement and Site Host Agreement.
5. Subject to Purchase Agreement. This Grant Agreement is executed and delivered pursuant to the Purchase Agreement and is subject to the terms and conditions of the Purchase Agreement..
6. Entire Agreement. This Grant Agreement and the Purchase Agreement embody the Parties' entire agreement and there have been and are no agreements, representations or warranties, or written between the Parties other than those set forth or provided for in this Agreement or the Purchase Agreement.
7. Headings. The headings used in this Grant Agreement are for purposes of convenience only and shall not be used in construing the provisions hereof.
8. Successors and Assigns. This Grant Agreement shall bind and benefit the respective successors and permitted assigns of Buyer and Seller.
9. Governing Law. This Grant Agreement shall be governed by, construed and enforced in accordance with the laws of the State of New York without giving effect to the choice of law principles thereof.
10. Modification. This Grant Agreement may not be modified or amended except by the written

agreement of Buyer and Seller.

11. Counterparts. This Grant Agreement may be executed in one or more counterparts, each of which shall be deemed to be an original, but all of which shall be one and the same document. A signed copy of this Agreement delivered by facsimile, e- mail or other means of electronic transmission shall be deemed to have the same legal effect as delivery of an original signed copy of this Grant Agreement. Electronic signatures using a nationally recognized service, such as DocuSign, is permitted.

IN WITNESS WHEREOF, the parties have caused this Grant Agreement to be executed as of the date first above written.

SELLER:
EV CHARGING SOLUTIONS, INC.

By: _____
Its:

PURCHASER:
AMPERAGE GROUP, LLC

By: _____
Its:



For: Energy Northwest , Attn Tanya Dion

MEMORANDUM OF UNDERSTANDING

Between

EV Charging Solutions, Inc. (“EVCS”)

and

Amperage Capital (“Amperage”)

This Memorandum of Understanding (“MOU”) is entered into and effective as of **December 30, 2025**, by and between EV Charging Solutions, Inc. (“EVCS”) and Amperage Capital (“Amperage”), collectively referred to as the “Parties,” and is provided to Energy Northwest to formally document the Parties’ respective responsibilities related to the Sedro-Woolley charging site under the applicable ZEVIP grant agreement.

1. Purpose

The purpose of this MOU is to document the Parties’ agreement regarding the allocation of ownership, operational, performance, and reporting responsibilities associated with the electric vehicle charging site located at 900 Metcalf St, Sedro-Woolley WA, 98284 known between Parties as **Sedro-Woolley – Metcalf Street** (“Site”) following Amperage’s purchase of the Site from EVCS, in alignment with the requirements of Washington State Department of Transportation Zero-Emission Vehicle Infrastructure Partnership (ZEVIP) Grant Agreement No. GCB 3974 (“ZEVIP Agreement”).

EVCS and Amperage intend to enter into a definitive purchase and sale agreement pursuant to which Amperage will acquire ownership of the Site from EVCS. Amperage Capital intends to continue operating the existing equipment at Performance Period and inherit the assignment

2. O&M Obligation Assignment

Pursuant to **ZEVIP Grant Agreement No. GCB 3974**, the Project is subject to a minimum **five-year Performance Period** during which the charging infrastructure must be operated, maintained, and made publicly accessible in accordance with program requirements.

Upon completion of the purchase of the Site, **Amperage shall assume responsibility for all Performance Period obligations related to ownership, operation, and maintenance of the Site**, including but not limited to:

- Operation and maintenance of the electric vehicle supply equipment in compliance with Section 10 and Section 11 of Agreement GCB 3974;
- Maintaining public accessibility, network functionality with 24/7 customer support, and required 97% uptime standards throughout the Performance Period;
- Performing necessary repairs, replacements, and annual preventative maintenance with qualified personnel to ensure continued compliance; and
- Take assignment of the existing Site Host Agreement expiring on 12/11/2035; and
- Cooperating with EVCS, WSDOT, and Energy Northwest to support ongoing compliance with the ZEVIP Agreement by way of audit, or documentation request

The five-year value of the network and maintenance obligations for the Site was estimated at **\$275,000** as a match-cost share to be provided by EVCS, which will now be provided by Amperage Capital and their operating partners.

3. Reporting and Grant Administration

Notwithstanding the transfer of Site ownership, **EVCS shall retain responsibility for all quarterly reporting, data submission, grant administration, and compliance communications required under ZEVIP Grant Agreement No. GCB 3974**, as part of EVCS's ongoing contractual and operational relationship with Energy Northwest, the Prime Contractor under the ZEVIP Agreement. EVCS intends to fully support Amperage Capital and Energy Northwest fulfill the entirety of the ZEVIP Agreement and continued operation.

Amperage agrees to provide EVCS with timely access to operational data, usage metrics, maintenance records, uptime information, and any other Site-related documentation reasonably necessary for EVCS to fulfill its reporting and compliance obligations under The Agreement.

4. Transition and Ongoing Cooperation

The Parties agree to cooperate in good faith to facilitate an orderly transition of Site ownership and ongoing operations, including the transfer of technical documentation, site records, and reasonable coordination necessary to maintain uninterrupted compliance with the ZEVIP Agreement and Site Host Agreement.

5. Conditional Understanding

Nothing in this MOU shall be construed as an assignment, novation, or transfer of EVCS's obligations under ZEVIP Grant Agreement No. GCB 3974 unless such assignment or assumption is expressly approved in writing by Energy Northwest and the Washington State Department of Transportation.

6. Term and Expiration

This MOU shall commence on **December 31st, 2025** and shall remain in effect for the duration of the ZEVIP Performance Period unless otherwise changed writing by Amperage Capital and Energy Northwest. The conclusion of this performance period shall **expire on December 11, 2030**, coinciding with the completion of the five-year Performance Period required under ZEVIP Grant Agreement No. GCB 3974.

EV Charging Solutions, Inc.

By: _____

Name:

Title:

Date:

Amperage Capital

By: Shannon Johnson

Name: Shannon Johnson

Title: CEO

Date: 12 / 31 / 2025

Acknowledged by:

Energy Northwest

By: _____

Name:

Title:

Date: